

Electronic pressure switch / sensor with two outputs

TSE3-D

p_{max} up to 400 bar (5800 PSI)



DNV·GL
dnvgl.com/af



Technical Features

- › Two switching outputs, one programmable as IO-Link, and one as a analogue current / voltage output
- › Red/green display for visualisation of the un/acceptable range
- › Rotating body for optimal position of connector
- › Long-term stability thanks to high overload protection
- › Robust design and stainless-steel body for use in harsh industrial environments
- › High vibration and shock resistance
- › UL approval and certification acc. to PED direction

Functional Description

Programmable pressure sensor with a metallic thin film measuring cell for measuring fluid system pressure, e.g. in hydraulic circuits, and indication of reaching the adjusted pressure value. The stainless-steel body is provided with connecting thread G 1/4 with FKM sealing ring. An electric connection is realized by four-pin connector M12 x 1. The 4-digit display and programming buttons are on the top surface. The sensor is suitable for industrial usage thanks to robust design, vibration and shock resistance.

Outputs:

OUT1 (pin 4): switching signal for indication of adjusted value of system pressure or Communication via IO-Link (COM2)

OUT2 (pin 2): switching signal for indication of adjusted value of system pressure or analogue signal 4 ... 20 mA / 0 ... 10 V

Technical Data

Application		
Measuring element		Metallic thin film measuring cell
Application		For industrial applications
Media		Liquids
Medium temperature	°C (°F)	-25 ... +80 (-13 ... +176)
Ambient temperature	°C (°F)	-25 ... +80 (-13 ... +176) [in case of cULus certification: -25 ... 60 (-13 ... +140)]
Storage temperature	°C (°F)	-40 ... +100 (-40 ... +212)
Pressure range	bar (PSI)	800 (11603)
Min. bursting pressure	bar (PSI)	1700 (24660)
Vacuum resistance	mbar (PSI)	-1000 (-14.5)
Measuring / setting range		
Measuring range	bar (PSI)	0 ... 400 (0 ... 5800)
Set point (SP)	bar (PSI)	1.5 ... 400 (21.8 ... 5800)
Reset point (rP)	bar (PSI)	1 ... 399.5 (14.5 ... 5790)
Analogue start point	bar (PSI)	0 ... 320 (0 ... 4640)
Analogue end point	bar (PSI)	80 ... 400 (1160 ... 5800)
In steps of	bar (PSI)	0.5 (7.3)
Electrical parameters		
Supply voltage	V DC	18 ... 30 (acc. to EN 50178 SELV/PELV)
Current consumption	mA	< 35
Min. insulation resistance	MΩ	100 (500 V DC)
Protection class		III
IP protection		IP65, IP67
Power-on delay time	s	0.3
Protection		Reverse polarity protection, integrated watchdog
Outputs		
Switching signal (pin 2, 4)		PNP / NPN switcher, normally open / closed contacts
Max. voltage drop switching output DC	V	2
Permanent current rating of switching output DC	mA	250
Switching frequency DC	Hz	< 500
Analogue current output (pin 2)	mA	4 ... 20 (scalable 1:5)
Max. load resistance	Ω	500
Analogue voltage output (pin 2)	V	0 ... 10 (scalable 1:5)
Min. load resistance	Ω	2000
Electric protection		Pulsed short-circuit and overload protection
Accuracy / deviations		
Switch point accuracy	%	< ± 0.4 (of the span); turn down 1:1
Repeatability	%	< ± 0.1 (of the span); with temperature fluctuations < 10 K; turn down 1:1
Characteristics deviation	%	< ± 0.25 (of the span) Best fit straight line (BFSL) < ± 0.5 (of the span) Limit value setting (LS)
Hysteresis deviation	%	< ± 0.1 (of the span)
Long-term stability	%	< ± 0.05 (of the span) per 6 months; turn down 1:1
Temperature coefficient zero point	%	0.2 (of the span / 10 K) in the range -25 ... +80 °C (-13 ... +176 °F)
Temperature coefficient span	%	0.2 (of the span / 10 K) in the range -25 ... +80 °C (-13 ... +176 °F)
Response times		
Response times	ms	< 1.5
Delay time programmable dS, dr	s	0 ... 50
Damping for the switching output dAP	s	0 ... 4
Damping for the analogue output dAA	s	0 ... 4
Max. response time analogue output	ms	3

Software /programming			Switching mode: hysteresis / windows; contacts normally open / closed; switch-on / switch-off delay; damping; display unit, current / voltage analogue output
Parameter setting options			
Interfaces			
Communication interface (pin 4)			IO-Link
Transmission type			COM2
IO-Link revision			1.1
SDCI standard			IEC 61131-9
IO-Link device ID			459 d /00 01 cb h
Profiles			Smart Sensor: Process Data Variable, Device Identification, Device Diagnosis
SIO mode			yes
Required master port type			A
Process data analogue			1
Process data binary			2
Min. process cycle time	ms		2.3
Tests / approvals			
EMC			DIN EN 61000-6-2, DIN EN 61000-6-3
Shock resistance			DIN EN 60068-2-27 50 g (11 ms)
Vibration resistance			DIN EN 60068-2-6 20 g (10 ...2000 Hz)
MTTF	years		129
UL approval			Approval No. J014
Pressure Equipment Directive			Sound Engineering Practice; can be used for group 2 fluids; group 1 fluids on request
Mechanical parameters			
Weight	kg (lbs)		0.26 (0.57)
Materials			Stainless steel 1.4542 (17-4 PH / 630) and 1.4404 (316L); PBT+PC-GF30; PBT-GF20;PC
Materials (wetted parts)			Stainless steel 1.4542 (17-4 PH / 630)
Min. pressure cycles			100 million
Tightening torque	Nm (lb.ft)		25 ... 35 (18.4 ... 25.8) (depends on lubrication, seal and pressure rating)
Circuit connection			External thread G 1/4 (DIN EN ISO 1179-2); Internal thread M5 for restrictor
Sealing ring			FKM (DIN 3869)
Display, operating elements			
Display unit			3x LED, green (bar, PSI, MPa)
Display switching status			2x LED yellow
Measured values			Alphanumeric display, red / green, 4-digit
Electrical connection			
Connector			4-pin; M12 x 1, contacts gold-plated

Dimensions in millimeters (inches)

TSE3-D

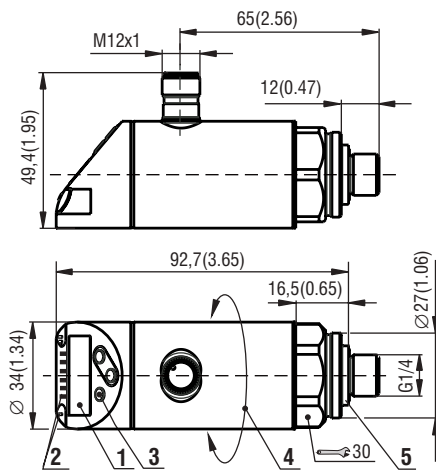

Electrical connection

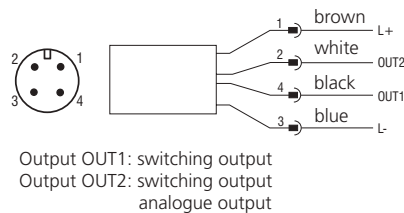

Connector without cable

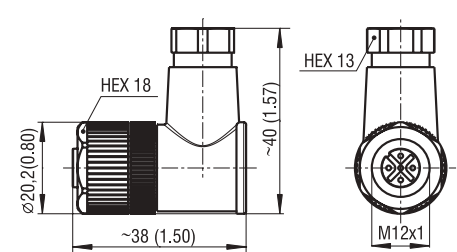

Connector with cable

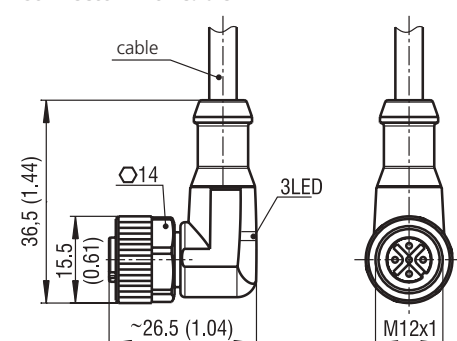

Ordering Code

TSE3-D - 400 - 2 - 1 - 1

Electronic pressure switch / sensor with two outputs

Setting / measuring range
0 - 400 bar (0 - 5800 PSI)

Number of output signals
switching output or IO-Link connection
switching or analogue output

Electrical connection
4 pin connector M12 x 1

Connection to the circuit
external thread G 1/4

Connector type	Ordering code
without cable	41349600
2m cable	41582300
5m cable	41825200

Connector is **not included** in order of any pressure switch or sensor and has to be ordered separately.