

Suction Filters**ES 094**

Tank top mounting · Connection G1¼ / -20 SAE · Nominal flow rate up to 70 l/min / 18.5 gpm



Suction Filter ES 094

Description**Application**

To be installed in the suction line of the pumps of hydraulic systems resp. upstream of the charge pumps of hydrostatic drives.

Performance features*Protection against wear:*

By means of filter elements that even in full-flow filtration meet the highest demands regarding cleanliness classes.

Protection against malfunction:

By means of full-flow filtration in the system return, the pumps above all are protected from dirt particles remaining in the system after assembly, repairs, or which are generated by wear or enter the system from outside.

Special features

- › By-pass valve:
The location close to the suction inlet prevents dirt particles retained by the filter element from entering into the clean oil side.
- › Filter element locking valve:
Ensures that dirt accumulated in the filter element is removed together with the element and cannot return to the tank.
- › Foot valve:
When the screw-on cap is removed for maintenance, the foot valve closes automatically. This makes it possible to service the filter even if it is submerged below the oil level in a full tank.

Filter elements

Flow direction from center to outside.

The star-shaped pleating of the filter material results in:

- › large filter surfaces
- › low pressure drop
- › high dirt-holding capacities
- › long service life

Filter maintenance

By using a clogging indicator the correct moment for maintenance is stated and guarantees the optimum utilization of the filter life.

Materials

Screw-on cap:	Polyester, GF reinforced
Filter head:	Aluminum alloy
Filter bowl:	Steel, phosphated
Seals:	NBR (FPM on request)
Filter media:	EXAPOR®MAX2 - inorganic microfiber web Paper – cellulose web, impregnated with resin

Accessories

Electrical and optical clogging indicators are available on request.
Dimensions and technical data see catalogue sheet 60.20.

Characteristics

Nominal flow rate

Up to 70 l/min / 18.5 gpm (see Selection Chart, column 2).
The nominal flow rates indicated by ARGO-HYTOS are based on the following features:

- › closed by-pass valve at $v \leq 200 \text{ mm}^2/\text{s}$ / 927 SUS
- › Element service life > 1000 operating hours at an average fluid contamination of 0.07 g per l/min / 0.27 g per gpm flow volume.
- › Flow velocity in the connection lines $\leq 1.5 \text{ m/s}$ / 4.9 ft/s.

If units, not equipped with a bypass valve, are used in hydro-static drives, the recommendations regarding their technical application given on catalog sheet 10.310 should be observed.

Connection

Threaded ports according to

- › ISO 228 or DIN 13
- › SAE standard J514

Sizes see Selection Chart, column 6,
(other port threads on request).

Filter fineness

16 $\mu\text{m(c)}$... 30 $\mu\text{m(c)}$
 β -values according ISO 16889
(see Selection Chart, column 4 and diagram Dx).

Dirt-holding capacity

Values in g test dust ISO MTD according to ISO 16889
(see Selection Chart, column 5).

Hydraulic fluids

Mineral oil and biodegradable fluids
(HEES and HETG, see info-sheet 00.20).

Temperature range

-30 °C ... +100 °C (temporary -40 °C ... +120 °C)
-22 °F ... +212 °C (temporary -40 °F ... + 248 °F)

Viscosity at nominal flow rate

- › at operating temperature: $v < 60 \text{ mm}^2/\text{s}$ / 280 SUS
- › start-up viscosity:
Determine v_{max} , observing the permissible pressure at the pump inlet according to diagram D; determine Δp as a function of the viscosity (take pressure loss in connection lines into account!)
- › at initial operation of units equipped with a by-pass valve:
The recommended starting viscosity can be read from the diagram D (pressure drop as a function of the kinematic viscosity) as follows: Find the 70% Δp of the cracking pressure of the by-pass valve on the vertical axis. Draw a horizontal line so that it intersects the Δp curve at a point. Read this point on the horizontal axis for the viscosity.

Mounting position

Vertical mounting to be preferred, suction opening pointing downwards, versions equipped with foot valve for horizontal mounting also.

Δp-curves for complete filters in Selection Chart, column 3

D1 Pressure drop as a function of the **flow volume** at $v = 35 \text{ mm}^2/\text{s}$ / 162 SUS (0 = casing empty)

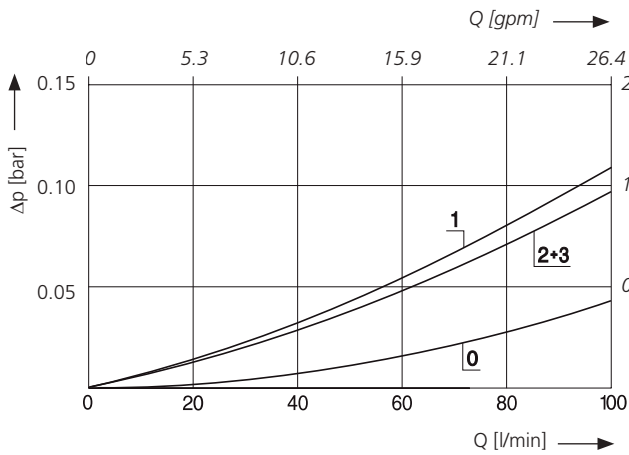

Pressure drop as a function of the **kinematic viscosity** at nominal flow

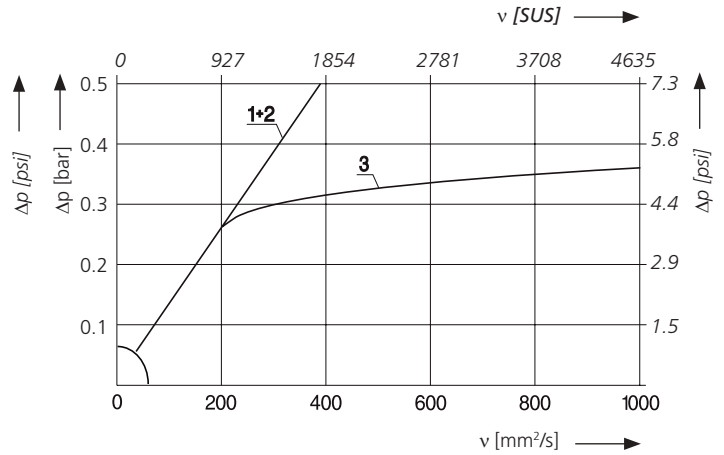

Filter fineness curves in Selection Chart, column 4

Dx Filtration ratio β as a function of particle size x obtained by the Multi-Pass-Test according to ISO 16889

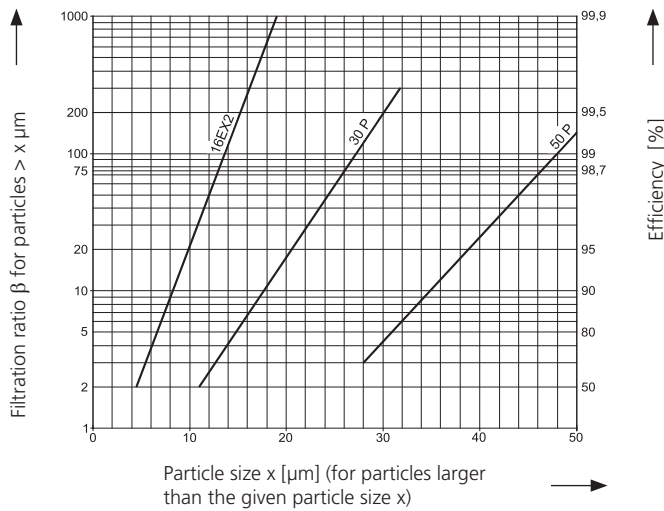

The abbreviations represent the following β -values resp. finenesses:

For EXAPOR®MAX2 and Paper elements:

- 16EX2 = $\bar{\beta}_{16(c)}$ = 200 EXAPOR®MAX 2
- 30P = $\bar{\beta}_{30(c)}$ = 200 Paper
- 50P = $\bar{\beta}_{50(c)}$ = 200 Paper

Based on the structure of the filter media of the 30P and 50P paper elements, deviations from the printed curves are quite probable.

For screen elements:

- 40S = screen material with mesh size 40 μm
- 60S = screen material with mesh size 60 μm
- 100S = screen material with mesh size 100 μm

Tolerances for mesh size according to DIN 4189.

For special applications, finenesses differing from these curves are also available by using special composed filter material.

Selection Chart

Part No.	Nominal flow rate	Pressure drop see diagram D1 /curve no.	Filter fineness see diagram Dx	Dirt-holding capacity	Connection B	Cracking pressure of by-pass	Foot valve	Symbol	Replacement filter element Part. No.	Weight	Remarks
1	l/min	3	4	g	6	7	8	9	10	11	12
ES 094-6801	60 ¹	D1/1	16EX2	40	G1¼	-	•	3	V2.0933-08	3.2	-
ES 094-6110	70 ¹	D1/2	30P	34	G1¼	-	-	1	P2.0933-01	3.0	-
ES 094-6111	70 ¹	D1/2	30P	34	G1¼	-	•	3	P2.0933-01	3.2	-
ES 094-6121	70	D1/3	30P	34	G1¼	-0.25	•	4	P2.0933-01	3.2	-

1	gpm	3	4	g	SAE	7	8	9	10	11	12
ES 094-6801	15.9 ¹	D1/1	16EX2	40	-20 ²	-	•	3	V2.0933-08	7.1	-
ES 094-6110	18.5 ¹	D1/2	30P	34	-20 ²	-	-	1	P2.0933-01	6.6	-
ES 094-6111	18.5 ¹	D1/2	30P	34	-20 ²	-	•	3	P2.0933-01	7.1	-
ES 094-6121	18.5	D1/3	30P	34	-20 ²	-3.63	•	4	P2.0933-01	7.1	-

¹ These values apply when used in hydrostatic drives in compliance with catalog sheet 10.310.

² Corresponds to 1⁵/₈-12 UN-2B

All filters are delivered with a plugged clogging indicator connection G¼.
As clogging indicators either manometers or vacuum switches can be used.
Extension pipes (available on request) adapt the filter length to various tank depths.

For the appropriate clogging indicator see catalog sheet 60.20.

Remarks:

- › The start of the red area respectively the actuating pressure of the vacuum switch has always to be higher than the cracking pressure of the by-pass valve (see Selection Chart, column 7).
- › Clogging indicators are optional and always delivered detached from the filter.
- › The filters listed in this chart are standard filters. Other designs available on request.

Dimensions

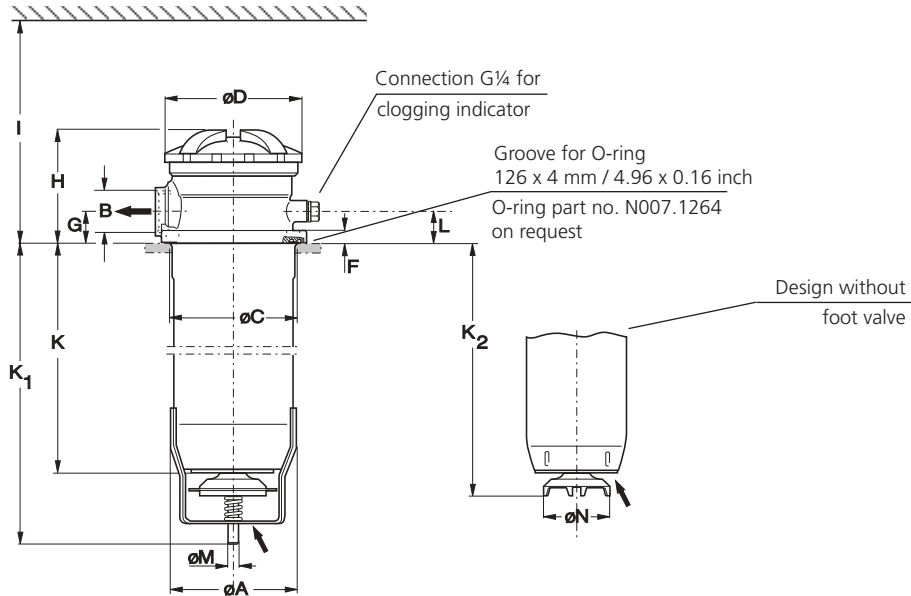

Design with 1 outlet port

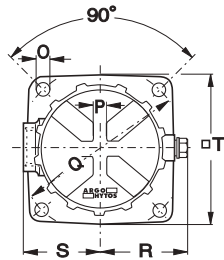

Design with 2 outlet ports on request

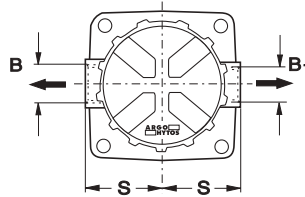

Required mounting surface

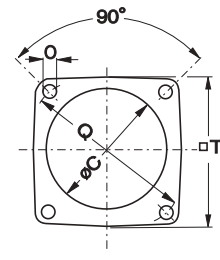

Measurements in mm

Type	A	B	C min./max.	D	E	F	G	H	I	K	K ₁
ES 094	115	G1¼	119/121	126.5	-	11.5	32	106	525	305	364

Type	K ₂	L	M	N	O	P	Q	R	S	T
ES 094	325	35	10	62.5	11	13	165	76.5	76	141

Measurements in inch

Type	A	B SAE	C min./max.	D	E	F	G	H	I	K	K ₁
ES 094	4.53	-20*	4.69/4.76	4.98	-	0.45	1.26	4.17	20.67	12.00	14.33

Type	K ₂	L	M	N	O	P	Q	R	S	T
ES 094	12.80	1.38	0.39	2.46	0.43	0.51	6.50	3.01	2.99	5.55

* Corresponds to 1½-12 UN-2B

Symbols

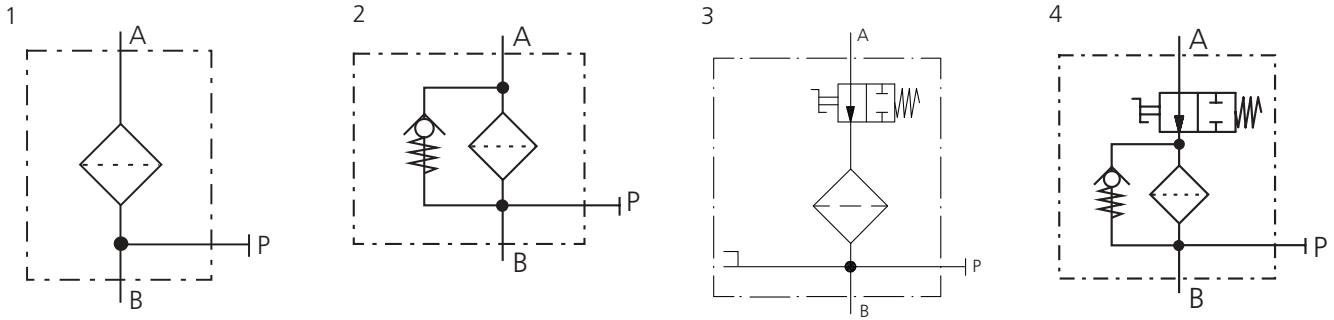

Spare Parts

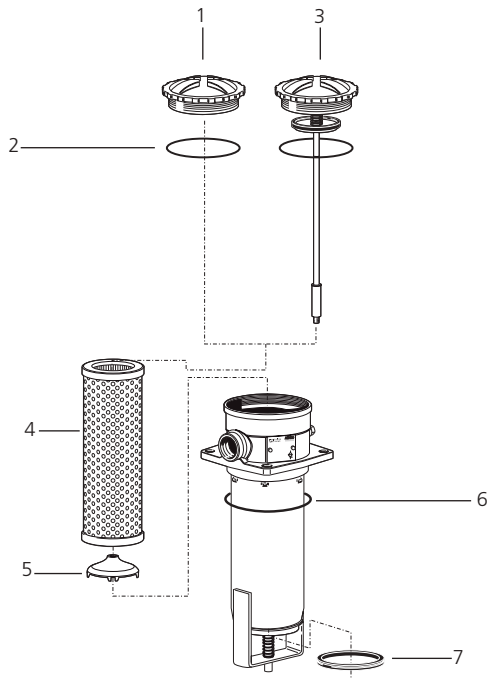

Pos.	Designation	Part No.
1	Screw-on cap with Pos. 2	ES 074.1212
2	O-ring 100 x 4 mm 3.94 x 0.16 inch	N007.1004
3	Screw-on cap with Pos. 2 for ES 094 (without by-pass) for ES 094 (with by-pass)	ES 094.1212 ES 094.1213
4	Replacement filter element	see Chart / col. 10
5	Valve cone	ES 074.0202
6	O-ring 126 x 4 mm* 4.96 x 0.16 inch*	N007.1264
7	Rubber ring	N042.7401

*not included in basic equipment

The functions of the complete filters as well as the outstanding features of the filter elements assured by ARGO-HYTOS can only be guaranteed if original ARGO-HYTOS spare parts are used.

Quality Assurance

Quality management according to DIN EN ISO 9001

To ensure constant quality in production and operation, ARGO-HYTOS filter elements undergo strict controls and tests according to the following ISO standards:

ISO 2941	Verification of collapse / burst pressure rating
ISO 2942	Verification of fabrication integrity (Bubble Point Test)
ISO 2943	Verification of material compatibility with fluids
ISO 3968	Evaluation of pressure drop versus flow characteristics
ISO 16889	Multi-Pass-Test (evaluation of filter fineness and dirt-holding capacity)
ISO 23181	Determination of resistance to flow fatigue using high viscosity fluid

Various quality controls during the production process guarantee the leakfree function and solidity of our filters.

Illustrations may sometimes differ from the original. ARGO-HYTOS is not responsible for any unintentional mistake in this specification sheet.