

High Pressure Filters
HD 037 · HD 057 · HD 077 · HD 097

In-line mounting · Operating pressure up to 500 bar / 7252 psi · Nominal flow rate up to 120 l/min / 31.7 gpm



High Pressure Filter HD 077

Description
Application

In the high-pressure circuits of hydraulic systems.

Performance features
Protection against wear:

By means of filter elements that even in full-flow filtration meet the highest demands regarding cleanliness classes.

Protection against malfunction:

By installation directly in front of the hydraulic components. The specific determined flow rate guarantees a closed by-pass valve even at $\leq 200 \text{ mm}^3/\text{s}$ / 927 SUS (cold start condition).

Filter elements

Flow direction from outside to center.

The star-shaped pleating of the filter material results in:

- › large filter surfaces
- › low pressure drop
- › high dirt-holding capacities
- › particularly long maintenance intervals

Filter maintenance

By using a clogging indicator, the correct moment for maintenance is stated and an optimal utilization of the filter service life is achieved.

Materials

Filter head:	Spheroidal graphite cast iron (SGI)
Filter bowl:	Cold extruded steel
Coating:	Powder paint resp. primed / phosphated
Seals:	NBR (FPM on request)
Filter media:	EXAPOR®MAX 2 - inorganic multi-layer microfiber web

Accessories

Electrical and / or optical clogging indicators are available on request. Dimensions and technical data see catalog sheet 60.40.

Operating pressure

0 ... 350 bar / 4352 psi, min. 2×10^6 pressure cycles
Nominal pressure according to DIN 24550

0 ... 500 bar / 7252 psi, min. 10^4 pressure cycles
Quasi-static operating pressure

Permissible pressures for other numbers of cycles

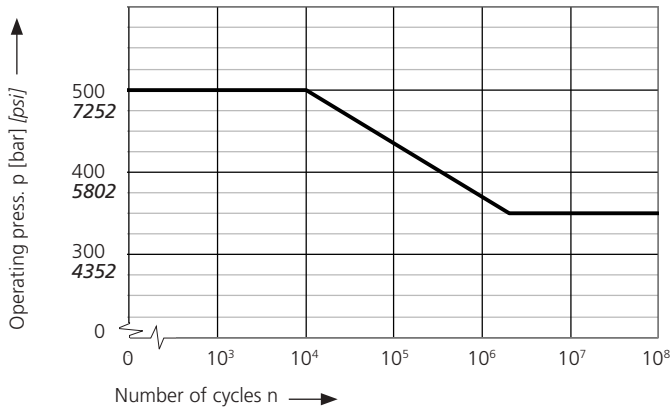

Nominal flow rate

Up to 120 l/min / 31.7 gpm (see Selection Charts, column 2)
The nominal flow rates indicated by ARGO-HYTOS are based on the following features:

- › closed by-pass valve at $v \leq 200 \text{ mm}^2/\text{s} / 927 \text{ SUS}$
- › element service life > 1000 operating hours at an average fluid contamination of 0.07 g per l/min / 0.27 g per gpm flow volume
- › flow velocity in the connection lines:
 - up to 250 bar $\leq 8 \text{ m/s} /$ up to 3626 psi $\leq 26.3 \text{ ft/s}$
 - > 250 bar $\leq 12 \text{ m/s} /$ > 3626 psi $\leq 39.4 \text{ ft/s}$

Filter fineness

10 $\mu\text{m(c)}$... 16 $\mu\text{m(c)}$
 β -values according to ISO 16889
(see Selection Charts, column 4 and diagram Dx).

Dirt-holding capacity

Values in g test dust ISO MTD according to ISO 16889
(see Selection Charts, column 5).

Hydraulic fluids

Mineral oil and biodegradable fluids
(HEES and HETG, see info-sheet 00.20).

Temperature range

-30 °C ... +100 °C (temporary -40 °C ... +120 °C)
-22 °F ... +212 °F (temporary -40 °F ... +248 °F)

Viscosity at nominal flow rate

- › at operating temperature: $v < 60 \text{ mm}^2/\text{s} / 280 \text{ SUS}$
- › as starting viscosity: $v_{\text{max}} = 1200 \text{ mm}^2/\text{s} / 5560 \text{ SUS}$
- › at initial operation:
The recommended starting viscosity can be read from the diagram D (pressure drop as a function of the kinematic viscosity) as follows: Find the 70% Δp of the cracking pressure of the by-pass valve on the vertical axis. Draw a horizontal line so that it intersects the Δp curve at a point. Read this point on the horizontal axis for the viscosity.

Mounting position

Preferably vertical, filter head on top.

Connection

Threaded ports according to

- › ISO 228 or DIN 13
- › SAE standard J514

Sizes see Selection Charts, column 6
(other port threads on request).

Δp -curves for complete filters in Selection Charts, column 3

D1 Pressure drop as a function of the **flow volume**
at $v = 35 \text{ mm}^2/\text{s} / 162 \text{ SUS}$ (0 = casing empty)

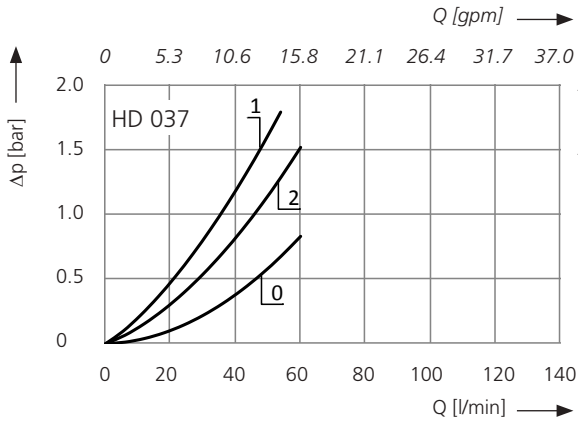

Pressure drop as a function of the **kinematic viscosity** at nominal flow

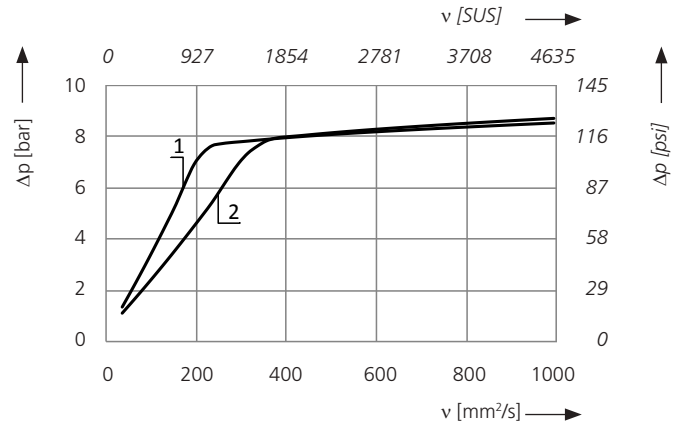

D2 Pressure drop as a function of the **flow volume**
at $v = 35 \text{ mm}^2/\text{s} / 162 \text{ SUS}$ (0 = casing empty)

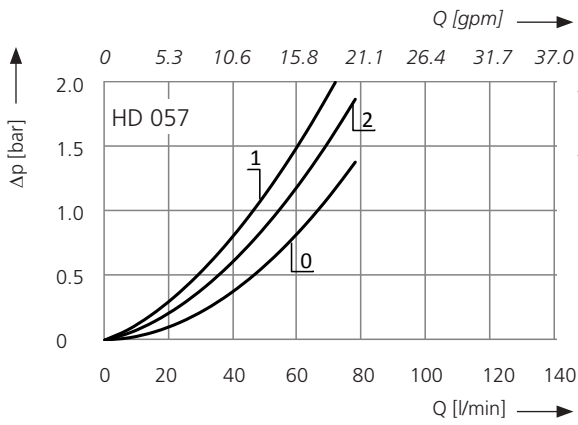

Pressure drop as a function of the **kinematic viscosity** at nominal flow

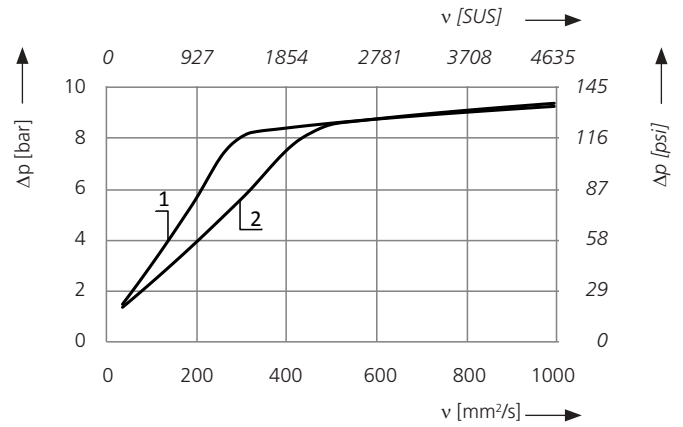

D3 Pressure drop as a function of the **flow volume**
at $v = 35 \text{ mm}^2/\text{s} / 162 \text{ SUS}$ (0 = casing empty)

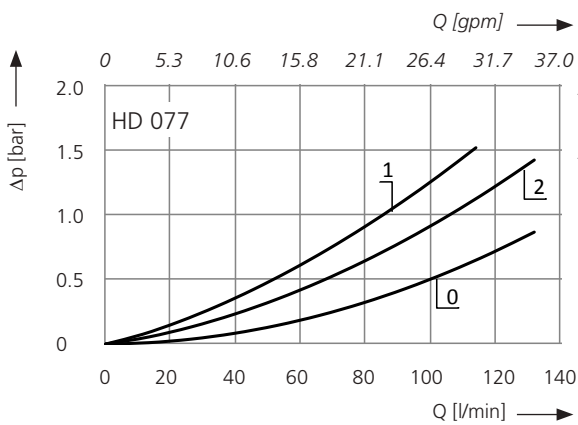

Pressure drop as a function of the **kinematic viscosity** at nominal flow

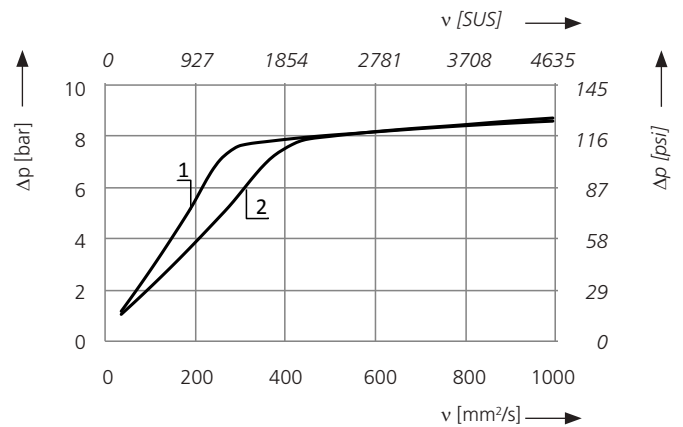

Δp-curves for complete filters in Selection Charts, column 3

D4 Pressure drop as a function of the **flow volume** at $v = 35 \text{ mm}^2/\text{s} / 162 \text{ SUS}$ (0 = casing empty)

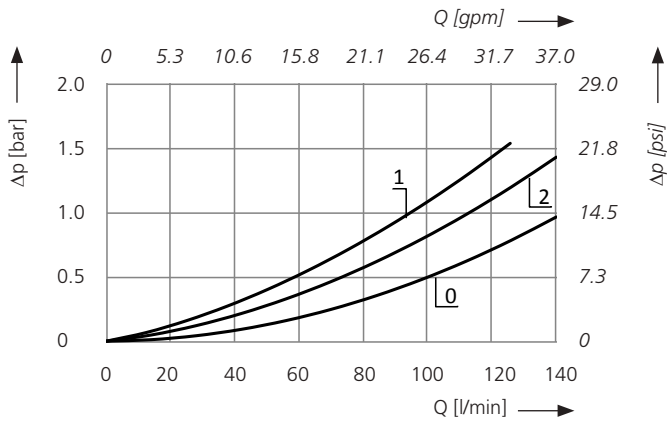

Pressure drop as a function of the **kinematic viscosity** at nominal flow

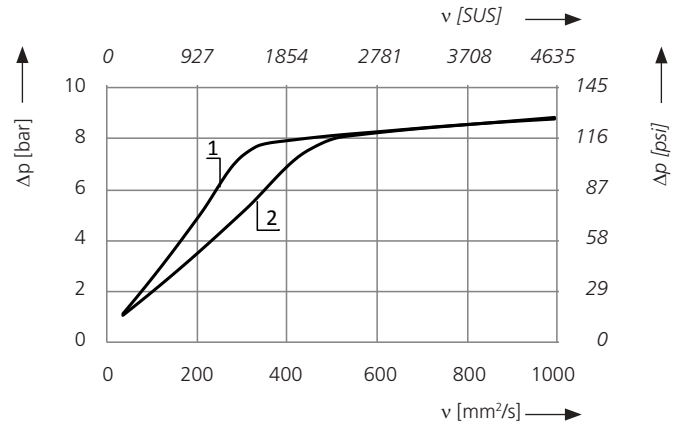

Filter fineness curves in Selection Charts, column 4

Dx Filtration ratio β as a function of particle size x obtained by the Multi-Pass Test according to ISO 16889

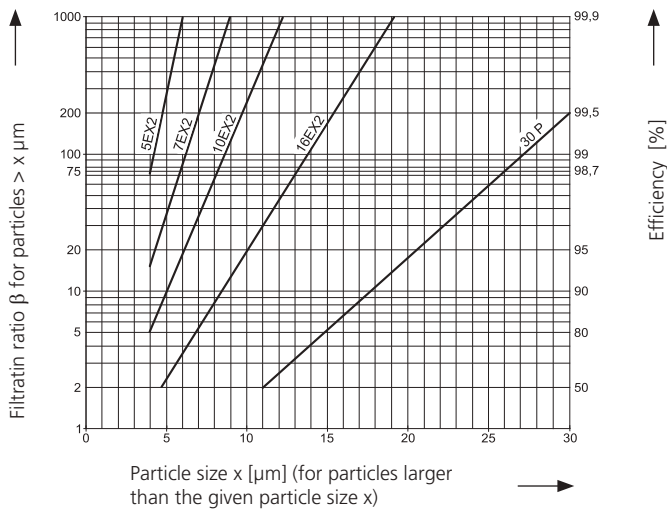

The abbreviations represent the following β -values resp. finenesses:

For EXAPOR®MAX2 and Paper elements:

- 5EX2 = $\bar{\beta}_{5(c)} = 200$ EXAPOR®MAX 2
- 7EX2 = $\bar{\beta}_{7(c)} = 200$ EXAPOR®MAX 2
- 10EX2 = $\bar{\beta}_{10(c)} = 200$ EXAPOR®MAX 2
- 16EX2 = $\bar{\beta}_{16(c)} = 200$ EXAPOR®MAX 2
- 30P = $\bar{\beta}_{30(c)} = 200$ Paper

Based on the structure of the filter media of the 30P paper elements, deviations from the printed curves are quite probable.

For screen elements:

- 40S = screen material with mesh size 40 μm
 - 60S = screen material with mesh size 60 μm
 - 100S = screen material with mesh size 100 μm
- Tolerances for mesh size according to DIN 4189

For special applications, finenesses differing from these curves are also available by using special composed filter media.

Selection Chart 1 of 2

Part No.	Nominal flow rate	Pressure drop see diagram D/Curve no.	Filter fineness diag. Dx	Dirt-holding capacity	Connection A/B	Cracking pressure of by-pass	Symbol	Replacement element Part No.	Weight	Clogging indicator Cracking pressure ()	Remarks
1	l/min	3	4	g	6	7	8	9	10	11	12
HD 037-156¹	45	D1/1	10EX2	7.3	G½	7	1	V3.0507-06	3.7	-	
HD 037-158¹	50	D1/2	16EX2	7.3	G½	7	1	V3.0507-08	3.7	-	
HD 037-168	50	D1/2	16EX2	7.3	G½	7	1	V3.0507-08	3.7	-	²
HD 057-156¹	60	D2/1	10EX2	12	G½	7	1	V3.0511-06	4.3	-	
HD 057-158¹	65	D2/2	16EX2	13	G½	7	1	V3.0511-08	4.3	-	
HD 057-168	65	D2/2	16EX2	13	G½	7	1	V3.0511-08	4.3	-	²
HD 077-156¹	95	D3/1	10EX2	16	G¾	7	1	V3.0515-06	4.9	-	
HD 077-158¹	110	D3/2	16EX2	19	G¾	7	1	V3.0515-08	4.9	-	
HD 097-156¹	105	D4/1	10EX2	23	G¾	7	1	V3.0522-06	5.4	-	
HD 097-158¹	120	D4/2	16EX2	25	G¾	7	1	V3.0522-08	5.4	-	

¹ Preferred type, no minimum order quantity required

² Housing primed / phosphated

Optical or electrical clogging indicators are available to monitor the clogging condition of the element. When ordering filters with integrated monitoring, the code of the clogging indicator (to be found in catalog sheet 60.40, column 2) has to be added to the part no. of the desired filter (basic unit).

For the appropriate clogging indicator see catalog sheet 60.40. The desired clogging indicator model is indicated by the code (Selection Charts, column 2).

Order example: The filter HD 057-158 is to be supplied with an optical indicator with automatic reset.

Order code: HD 057-158 OD1

Part No. (basic unit) _____

Clogging indicator (code) _____

Remarks:

- › The switching pressure of the clogging indicator has always to be lower than the cracking pressure of the by-pass valve (see Selection Charts, column 7).
- › For versions with electrical clogging indicator, the device socket is not included in the scope of delivery.
- › For the electrical clogging indicator of type ED8, a transparent device socket with two LEDs is available, which additionally enables visual indication of the filter contamination (order no. DG 041.1200).
- › The filters listed in this chart are standard filters. Other designs, e.g. without bypass or with horizontal oriented clogging indicator, available on request.

Selection Chart 1 of 2

Part No.	Nominal flow rate	Pressure drop see diagram D /curve no.	Filter fineness see diagr. Dx	Dirt-holding capacity	Connection A/B	Cracking pressure of by-pass	Symbol	Replacement element Part No.	Weight	Clogging indicator Cracking pressure ()	Remarks
	gpm		g	SAE	psi				lbs		
1	2	3	4	5	6	7	8	9	10	11	12
HD 037-756¹	11.9	D1/1	10EX2	7.3	-8 ³	102	1	V3.0507-06	8.2	-	
HD 037-758¹	13.2	D1/2	16EX2	7.3	-8 ³	102	1	V3.0507-08	8.2	-	
HD 037-768	13.2	D1/2	16EX2	7.3	-8 ³	102	1	V3.0507-08	8.2	-	²
HD 057-756¹	15.9	D2/1	10EX2	12	-8 ³	102	1	V3.0511-06	9.5	-	
HD 057-758¹	17.2	D2/2	16EX2	13	-8 ³	102	1	V3.0511-08	9.5	-	
HD 057-768	17.2	D2/2	16EX2	13	-8 ³	102	1	V3.0511-08	9.5	-	²
HD 077-756¹	25.1	D3/1	10EX2	16	-12 ⁴	102	1	V3.0515-06	10.8	-	
HD 077-758¹	29.1	D3/2	16EX2	19	-12 ⁴	102	1	V3.0515-08	10.8	-	
HD 097-756¹	27.7	D4/1	10EX2	23	-12 ⁴	102	1	V3.0522-06	11.9	-	
HD 097-758¹	31.7	D4/2	16EX2	25	-12 ⁴	102	1	V3.0522-08	11.9	-	

¹ Preferred type, no minimum order quantity required

² Housing primed / phosphated

³ Corresponds to 3/4 UNF-2B

⁴ Corresponds to 1 1/16-12 UN-2B

Optical or electrical clogging indicators are available to monitor the clogging condition of the element. When ordering filters with integrated monitoring, the code of the clogging indicator (to be found in catalog sheet 60.40, column 2) has to be added to the part no. of the desired filter (basic unit).

For the appropriate clogging indicator see catalog sheet 60.40. The desired clogging indicator model is indicated by the code (Selection Charts, column 2).

Order example: The filter HD 057-758 is to be supplied with an optical indicator with automatic reset.

Order code: HD 057-758 OD1

Part No. (basic unit) _____

Clogging indicator (code) _____

Remarks:

- › The switching pressure of the clogging indicator has always to be lower than the cracking pressure of the by-pass valve (see Selection Charts, column 7).
- › For versions with electrical clogging indicator, the device socket is not included in the scope of delivery.
- › For the electrical clogging indicator of type ED8, a transparent device socket with two LEDs is available, which additionally enables visual indication of the filter contamination (order no. DG 041.1200).
- › The filters listed in this chart are standard filters. Other designs, e.g. without bypass or with horizontal oriented clogging indicator, available on request.

Dimensions

Version with integrated optical clogging indicator OD1

Version with integrated electrical clogging indicator ED8 with device socket*

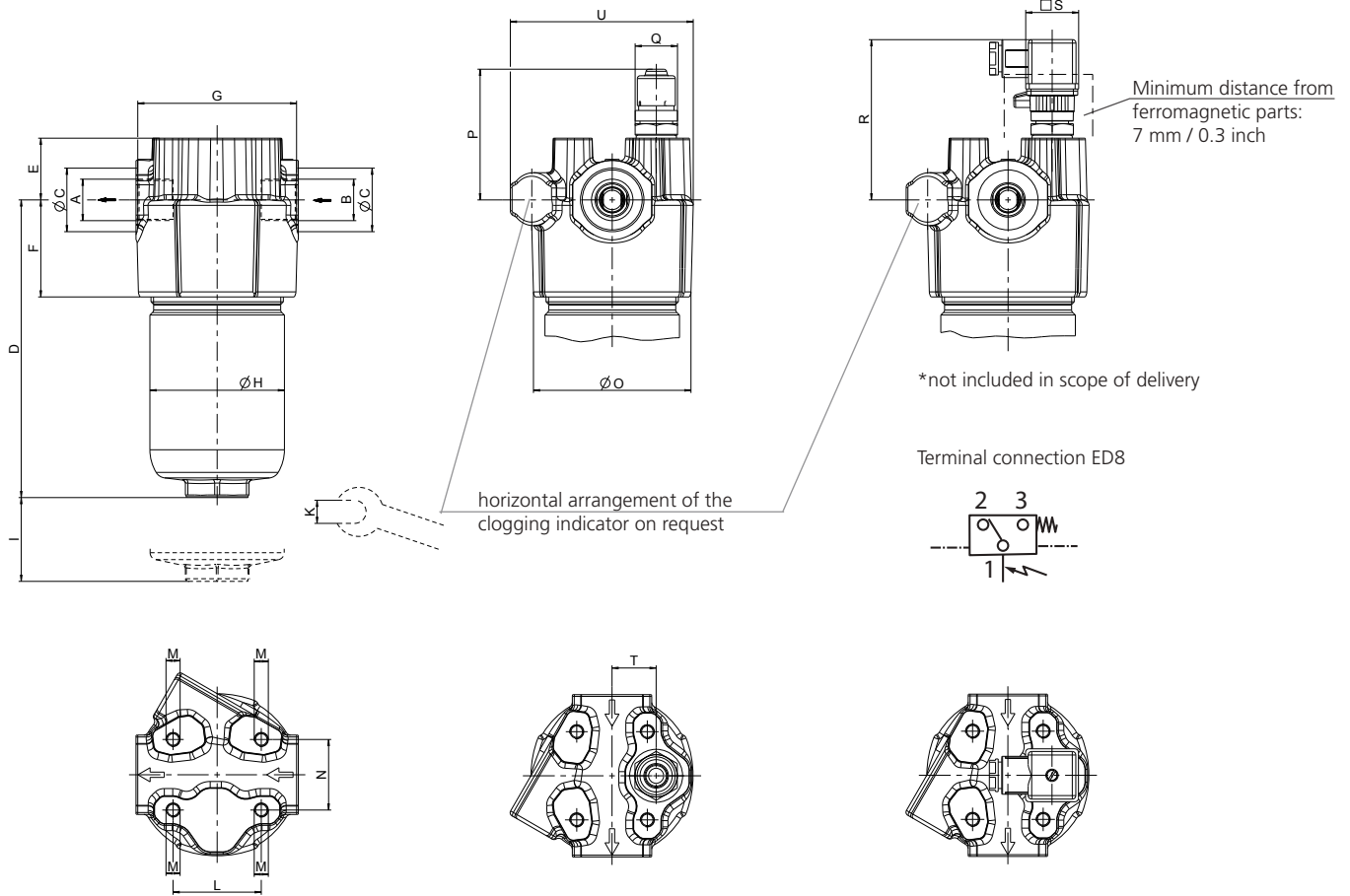

Measurements in mm

Type	A/B	C	D	E	F	G	H	I	K	L	M Ødepth	N	O	P	Q	R	S	T	U
HD 037	G½	34	122	35	55	90	76	57	AF36	50	M8 / 16	40	90	72.5	AF24	89.5	□ 30	25	91
HD 057	G½	34	168	35	55	90	76	57	AF36	50	M8 / 16	40	90	72.5	AF24	89.5	□ 30	25	91
HD 077	G¾	36	219	35	55	90	76	57	AF36	50	M8 / 16	40	90	72.5	AF24	89.5	□ 30	25	91
HD 097	G¾	36	261	35	55	90	76	57	AF36	50	M8 / 16	40	90	72.5	AF24	89.5	□ 30	25	91

Measurements in inch

Type	A/B SAE	C	D	E	F	G	H	I	K mm	L	M Ødepth	N	O	P	Q mm	R	S	T	U
HD 037	-8 ¹	1.33	4.76	1.37	2.15	3.51	2.96	2.22	AF36	1.95	³	1.56	3.51	2.83	AF24	3.49	□ 1.18	0.98	3.55
HD 057	-8 ¹	1.33	6.55	1.37	2.15	3.51	2.96	2.22	AF36	1.95	³	1.56	3.51	2.83	AF24	3.49	□ 1.18	0.98	3.55
HD 077	-12 ²	1.40	8.54	1.37	2.15	3.51	2.96	2.22	AF36	1.95	³	1.56	3.51	2.83	AF24	3.49	□ 1.18	0.98	3.55
HD 097	-12 ²	1.40	10.18	1.37	2.15	3.51	2.96	2.22	AF36	1.95	³	1.56	3.51	2.83	AF24	3.49	□ 1.18	0.98	3.55

¹ Corresponds to ¾ UNF-2B

² Corresponds to 1 1/16-12 UN-2B

³ 5/16-18 UNC-2B / 0.63

Symbols

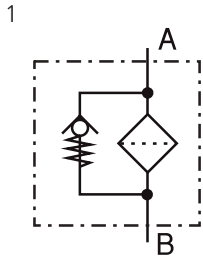

Spare Parts

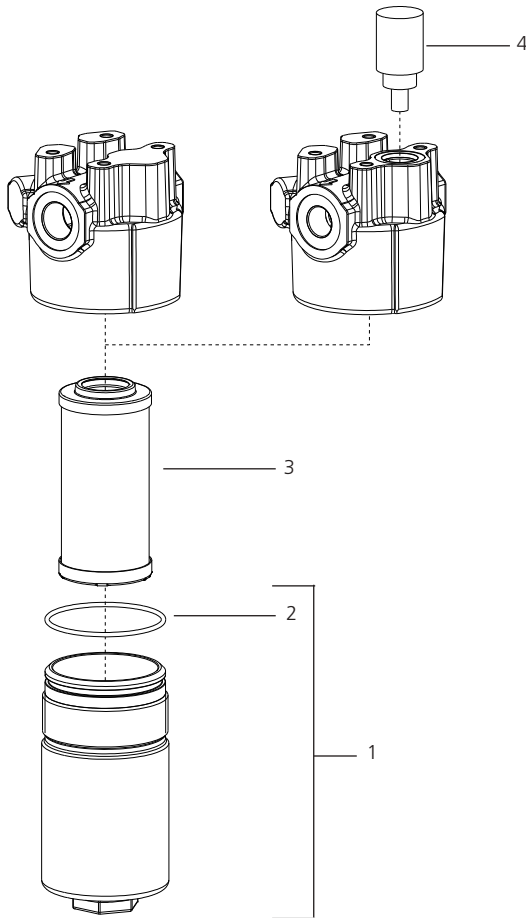

Pos.	Designation	Part No.
1	Filter bowl HD 037 (with pos. 2)	HD 037.0701
1	Filter bowl HD 057 (with pos. 2)	HD 057.0701
1	Filter bowl HD 077 (with pos. 2)	HD 077.0701
1	Filter bowl HD 097 (with pos. 2)	HD 097.0701
2	O-ring 66 x 2.62 mm 2.60 x 0.10 inch	N007.0673
3	Replacement filter element	see Chart/col. 9
4	Clogging indicator	see catalog sheet 60.40

The functions of the complete filters as well as the outstanding features of the filter elements assured by ARGO-HYTOS can only be guaranteed if original ARGO-HYTOS spare parts are used.

Quality Assurance

Quality management according to DIN EN ISO 9001

To ensure constant quality in production and operation, ARGO-HYTOS filter elements undergo strict controls and tests according to the following ISO standards:

ISO 2941	Verification of collapse / burst pressure rating
ISO 2942	Verification of fabrication integrity (Bubble Point Test)
ISO 2943	Verification of material compatibility with fluids
ISO 3968	Evaluation of pressure drop versus flow characteristics
ISO 16889	Multi-Pass-Test (evaluation of filter fineness and dirt-holding capacity)
ISO 23181	Determination of resistance to flow fatigue using high viscosity fluid

Before release into the series production the filter casing is tested for fatigue strength in our pressure pulse test rig. Various quality controls during the production process guarantee the leakfree function and solidity of our filters.

Illustrations may sometimes differ from the original. ARGO-HYTOS is not responsible for any unintentional mistake in this specification sheet.