

**Technical Features**

- > Hardened precision parts
- > Sharp-edged steel seats for dirt-tolerant performance
- > Leak-free closing, suitable for fast cycling with long life
- > High flow capacity
- > Optional bias spring ranges for back-pressure control
- > In the standard version, the valve is zinc-coated for 520 h protection acc. to ISO 9227

**Functional Description**

A hydraulic check valve in the form of a screw-in cartridge-style for use as a blocking or load-holding device. The cartridge has a ball check which is closed by spring until sufficient pressure is applied at port 1 to open flow to port 2.



**Technical Data**

Valve size / Cartridge cavity		3/4-16 UNF-2A / A2 (C-8-2)			
Max. flow	l/min (GPM)	40 (10.6)			
Max. operating pressure	bar (PSI)	420 (6090)			
Cracking pressure	bar	0.5	1.5	3.5	7.0
	(PSI)	(7.3)	(21.8)	(50.8)	(101.5)
Fluid temperature range (NBR)	°C (°F)	-30 .... +100 (-22 ... +212)			
Fluid temperature range (FPM)	°C (°F)	-20 .... +120 (-4 ... +248)			
Weight	kg (lbs)	0.06 (0.13)			

		Datasheet	Type
General information		GI_0060	Products and operating conditions
Valve bodies	In-line mounted	SB_0018	SB-A2*
	Sandwich mounted	SB-04(06)_0028	SB-*A2*
Cavity details / Form tools		SMT_0019	SMT-A2*
Spare parts		SP_8010	

**Characteristics** measured at  $v = 32 \text{ mm}^2/\text{s}$  (156 SUS)

**Pressure drop related to flow rate**

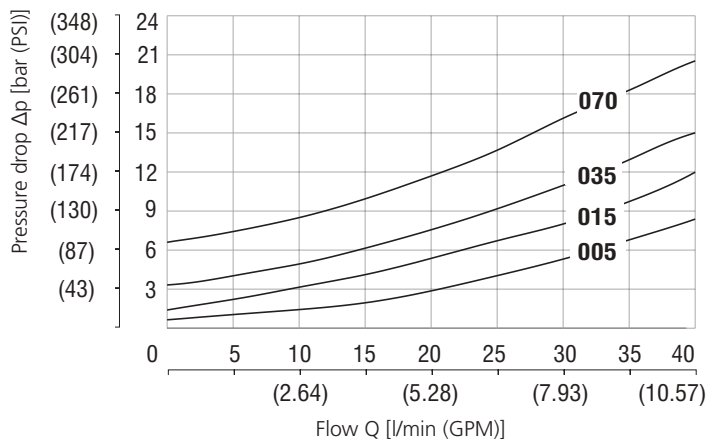

**Dimensions** in millimeters (inches)

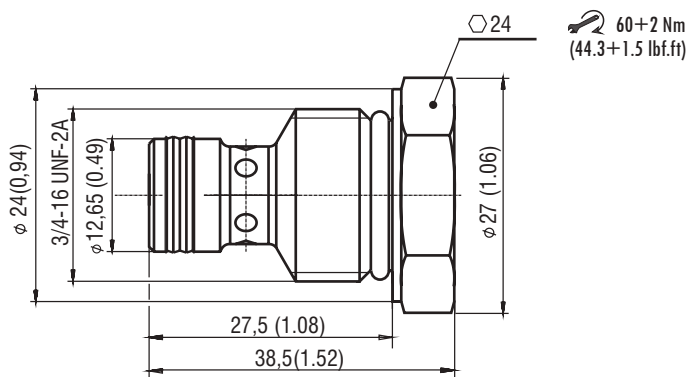

**Ordering Code**

	<b>SC1F - A2 / H</b>	<input type="checkbox"/>	<input type="checkbox"/>	<b>- B</b>	
<b>Check valve, ball type</b>					
<b>Valve cavity</b> 3/4-16 UNF (C-8-2)					
<b>Model</b> High performance					
		<b>000</b>			
		<b>002</b>			
		<b>005</b>			
		<b>015</b>			
		<b>035</b>			
		<b>070</b>			
				<b>No designation</b> V	
					<b>Surface treatment</b> zinc-coated (ZnNi), ISO 9227 (520 h)
					<b>Seals</b> NBR FPM (Viton)
					<b>Cracking pressure</b> without spring 0.2 bar (2.9 PSI) 0.5 bar (7.3 PSI) 1.5 bar (21.8 PSI) 3.5 bar (50.8 PSI) 7.0 bar (101.5 PSI)