

ISO 15552
PNÖMATİK SİLİNDİRLER
DMC SERİSİ Ø32 - Ø100



**DMC SERİSİ**

ISO 15552 - Ø32 - Ø100

MANYETİK YASTIKLAMALI SİLİNDİR

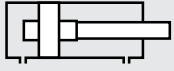
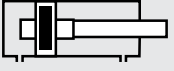
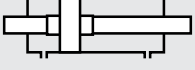
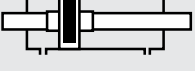
OPTİMUM FİYAT,
MAKSİMUM PERFORMANS**DMC:** ÇİFT ETKİLİ
YASTIKLAMALI SİLİNDİR**DMC-A:** ÇİFT ETKİLİ
YASTIKLAMALI MANYETİK SİLİNDİR**DMC-D:** ÇİFT ETKİLİ
YASTIKLAMALI ÇİFT MİLLİ SİLİNDİR**DMC-AD:** ÇİFT ETKİLİ
YASTIKLAMALI MANYETİK
ÇİFT MİLLİ SİLİNDİR

Bu ürünlerde yastıklama standarttır.

Kuvvet değeri:

Silindir Ø mm	Mil Ø mm	İtme ve Çekme kuvvetleri (6 Bar)	
		İtme kuvveti (N)	Çekme kuvveti (N)
32	12	482	4
40	16	754	
50	20	1178	9
63	20	1870	1682
80	25	3016	2721
100	25	4712	441

Sipariş örneği:DMC-A

Ürün kodu

050-0100

Silindir Ø Strok

ABSilindir
bağlantılarıM1Standart dışı
varyasyonlar**Standart dışı varyasyonlar:**

- R1: Paslanmaz çelik silindir mili (SS 304, SS 316)
- R3: Kapak bağlantı civataları paslanmaz çelik (SS 304)
- R4: Mil ucu somunu paslanmaz çelik (SS 304)
- R5: Silindir mili CK 45 çelik (sert krom kaplamalı)
- M1: Silindir milinde uzatılmış erkek diş
- M2: Dişi diş açılmış silindir mili
- M3: Silindir mili özel diş ölçüsü
- M4: Uzatılmış silindir mili
- E1: Korozyona karşı dayanıklı alüminyum kapaklar
(sert eloksallı kaplamalı)
- K1: Maks. 150°C için sızdırmazlık elemanları (viton)
- K2: Mil keçesi NBR+PA
- K3: Sızdırmazlık elemanları NBR
- K4: Mil keçesi viton

Çalışma akışkanı:

Filtrelenmiş ve yağlanmış ya da filtrelenmiş ve yağsız hava

Çalışma sıcaklık derecesi:

Poliüretan (PU) : (-20°C) - (+80°C)

Viton (FKM) : (-30°C) - (+150°C)

Maksimum çalışma basıncı:

10 Bar

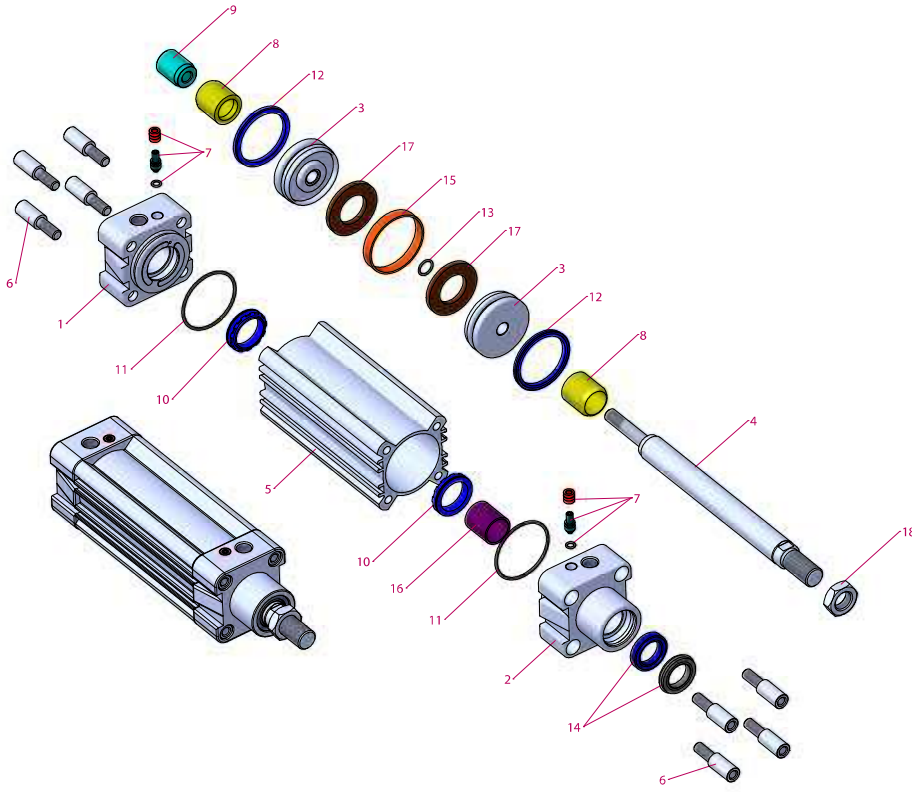
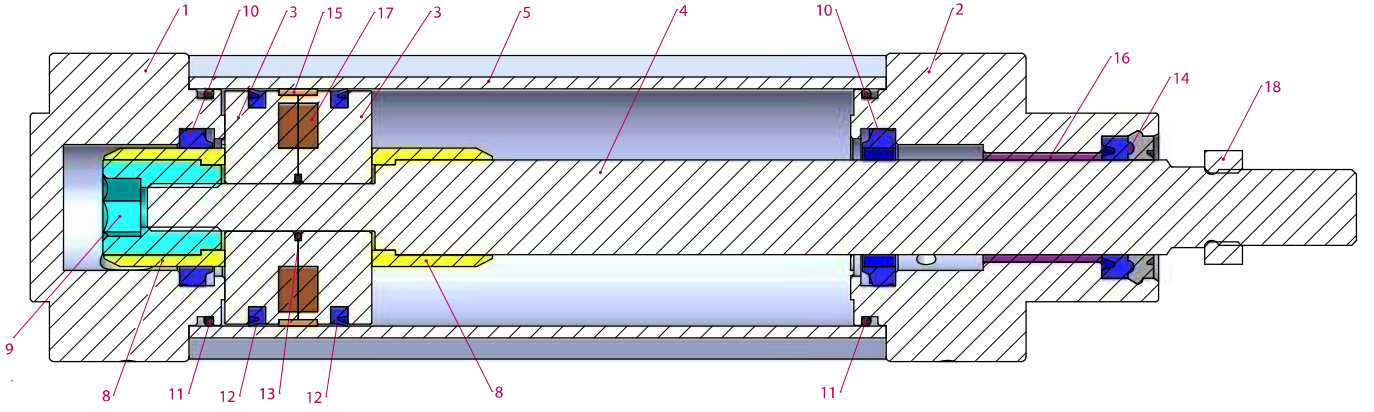

No	Malzeme adı	Malzeme özelliği	Adedi
1	Arka kapak	Alüminyum	1
2	Ön kapak	Alüminyum	1
3	Orta piston	Alüminyum	2
4	Piston mili	X20 Cr13 Sert Krom kaplamalı	1
5	Boru	Al Mg Si 0,5 + Eloksal kaplamalı	1
6	Civata	Galvaniz kaplamalı çelik	8
7	Yastıklama vidası	Pirinç + AISI 303 NBR	2
8	Yastıklama plastiği	Polyacetal	2
9	Yastıklama dişlisi	Galvaniz kaplamalı çelik	1
10	Yastıklama keçesi	PU	2
11	Kapak O-ringi	NBR	2

No	Malzeme adı	Malzeme özelliği	Adedi
12	Piston keçesi	PU	2
13	Orta piston O-ringi	NBR	1
14	Mil keçesi	HYTREL + PU	1
15	Yataklama bandı	Polyacetal	1
16	Yataklama burcu	CSB-40	1
17	Miknatis		2
18	Somun	Galvaniz kaplamalı çelik	1

Not:

Çap 32'de yastıklama plastiği yerine yastıklama sarı, yastıklama plastiği dişlisi yerine ise yastıklama sarı dişlisi kullanılmaktadır. (Malzeme: Pirinç)

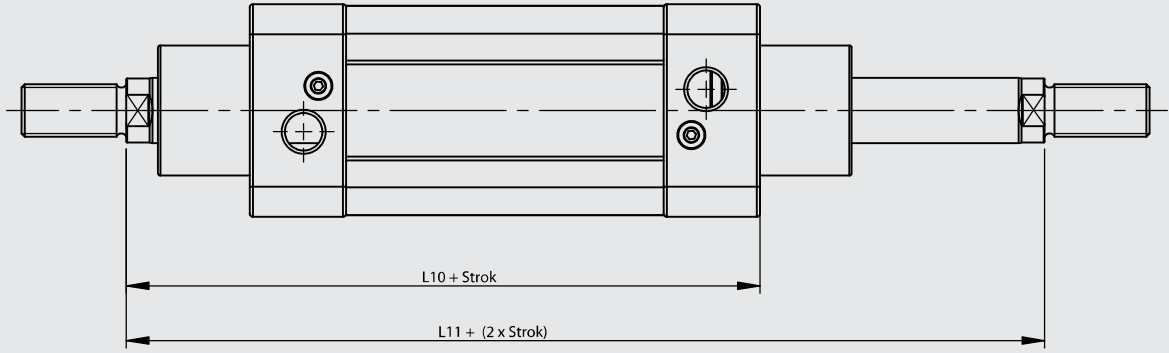
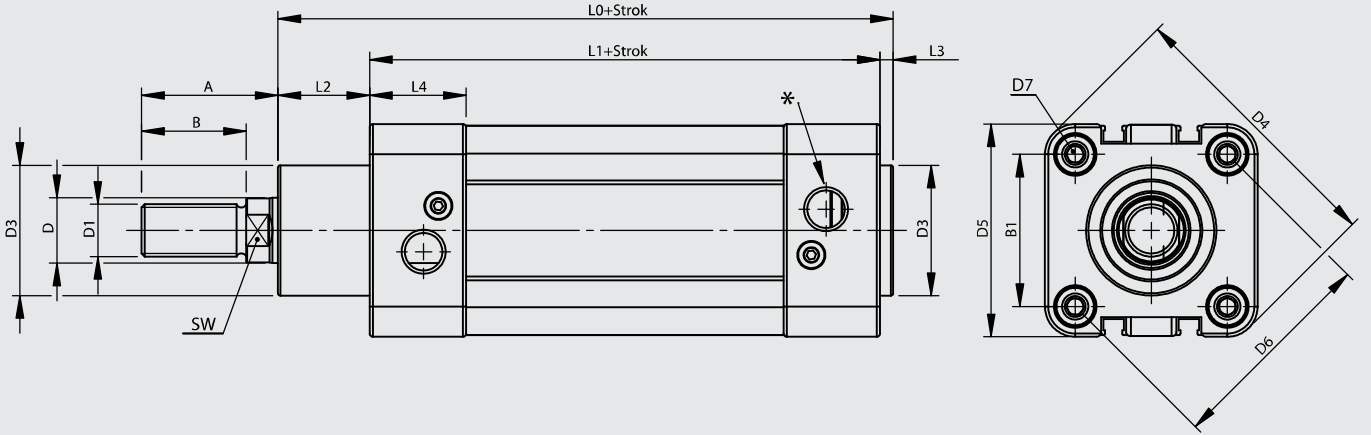

Silindir Ø mm	A	B	B1	D Ø	D1	D3 Ø	D4	D5	D6 Ø	D7	L0	L1	L2	L3	L4	L10	L11	SW	*
32	30	22	32.5	12	M10x1.25	30	59	45	46	M6	116	94	18	4	25	120	146	10	G1/8"
40	34	24	38	16	M12x1.25	35	70,2	54	53.7	M6	129	105	20	4	27	135	165	13	G1/4"
50	41	32	46.5	20	M16x1.5	40	84,2	65	65.7	M8	138	106	28	4	29.5	143	180	17	G1/4"
63	42	32	56.5	20	M16x1.5	45	99,5	76	80	M8	152	121	27	4	34,5	158	195	17	G3/8"
80	52	40	72	25	M20x1.5	45	123.8	94	101.8	M10	167	128	34	4	35	174	220	22	G3/8"
100	52.5	40	89	25	M20x1.5	55	148.8	112	125.9	M10	182.5	138	38.5	4	38	189	240	22	G1/2"

FB Flanş Bağlantı

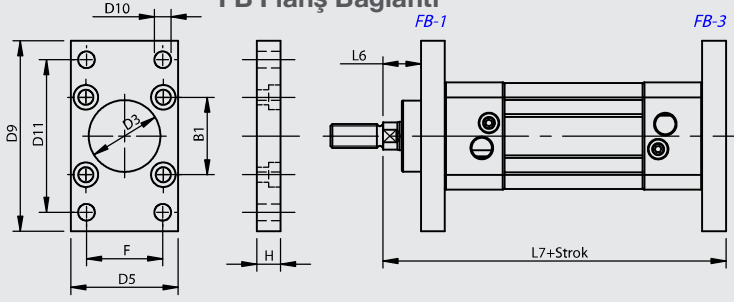

OEKB Orta Eklem Kapak Bağlantılı

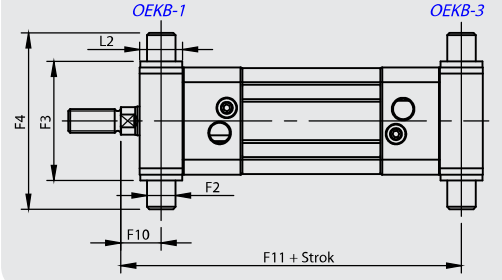

AB Ayak Bağlantı

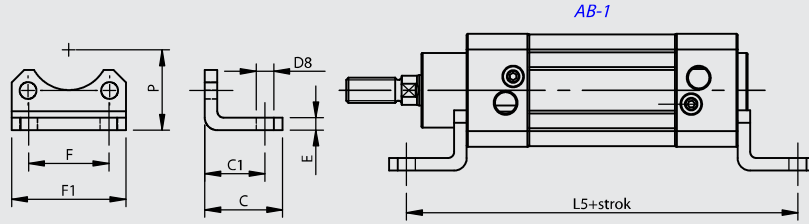

EB Eklem Bağlantı

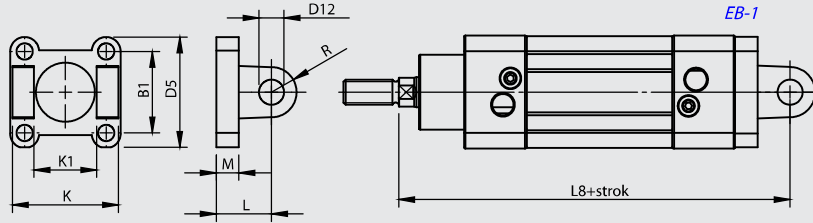

YB Yer Bağlantı

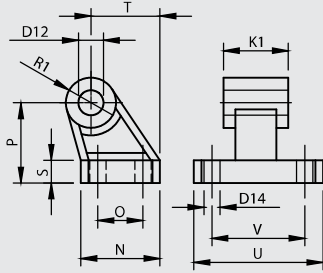

EYB Eklem Yer Bağlantı

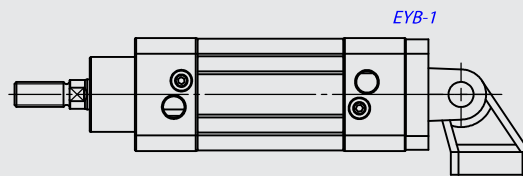

Silindir Ø mm	B1	C	C1	D3 Ø H11	D5	D8 Ø H14	D9	D10 Ø H13	D11 JS14	D12 Ø H9	D14 Ø H13	E	F JS14	F1	F2 Ø e9	F3 h14	F4	F10	F11
32	32.5	30	24	30	45	7	80	7	64	10	6.6	5	32	45.5	12	50	74	17	129
40	38	37	28	35	54	10	90	9	72	12	6.6	5	36	54.5	16	63	95	20	145
50	46.5	41	32	40	65	10	110	9	90	12	9	6	45	65	16	75	107	23	157
63	56.5	44	32	45	76	10	120	9	100	16	9	6	50	76	20	90	130	23.5	171.5
80	72	56	41	45	94	12	150	12	126	16	11	6	63						
100	89	58	41	55	112	14	175	14	150	20	11	6	75	112	25	132	182	31.8	208.3

Silindir Ø mm	H	K h14	K1 H14	L	L2	L5	L6	L7	L8	M	N	O JS14	P JS16	R	R1	S	T	U	V JS14
32	10	45	26	22	18	142	16	130	142	9	31	18	32	10	10	8	27.5	51	38
40	10	52	28	25	20	161	20	145	160	9	35	22	36	12	11	10	30.5	54	41
50	12	60	32	27	28	170	25	155	170	11	45	30	45	13	13	12	40.5	65	50
63	12	70	40	32	27	185	25	170	190	11	50	35	50	16	15	12	44.5	67	52
80	16	90	50	36	34	210	30	190	210	14	60	40	63	16	15	14	57	86	6
100	16	110	60	41	38.5	220	35	205	230	14	70	50	71	20	19	15	65	96	76

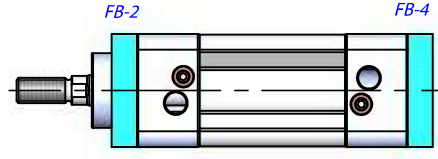
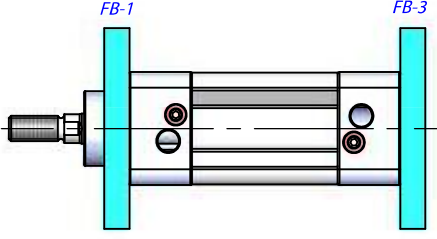
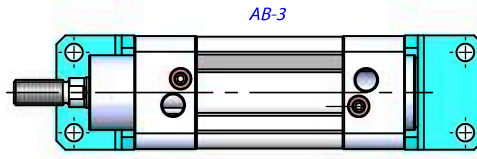
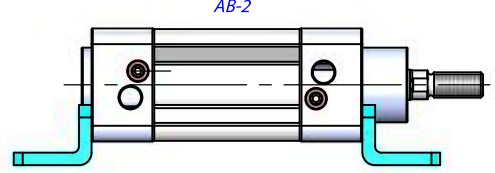
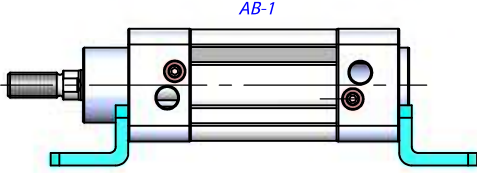
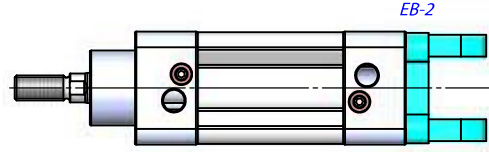
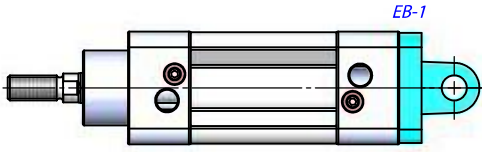
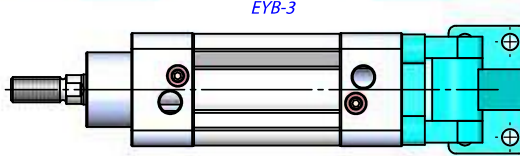
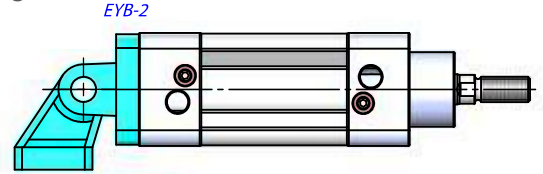
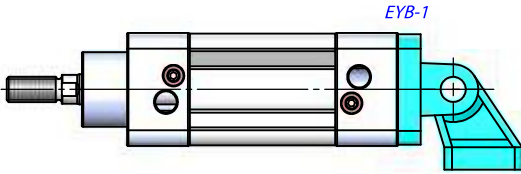
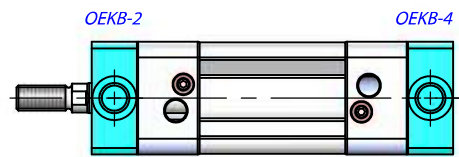
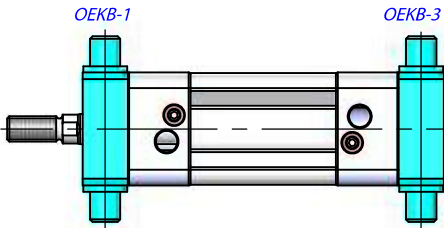
FB Flanş Bağlantı**AB Ayak Bağlantı****EB Eklem Bağlantı****EYB Eklem Yer Bağlantı****OEKB Orta Eklem Kapak Bağlantılı**

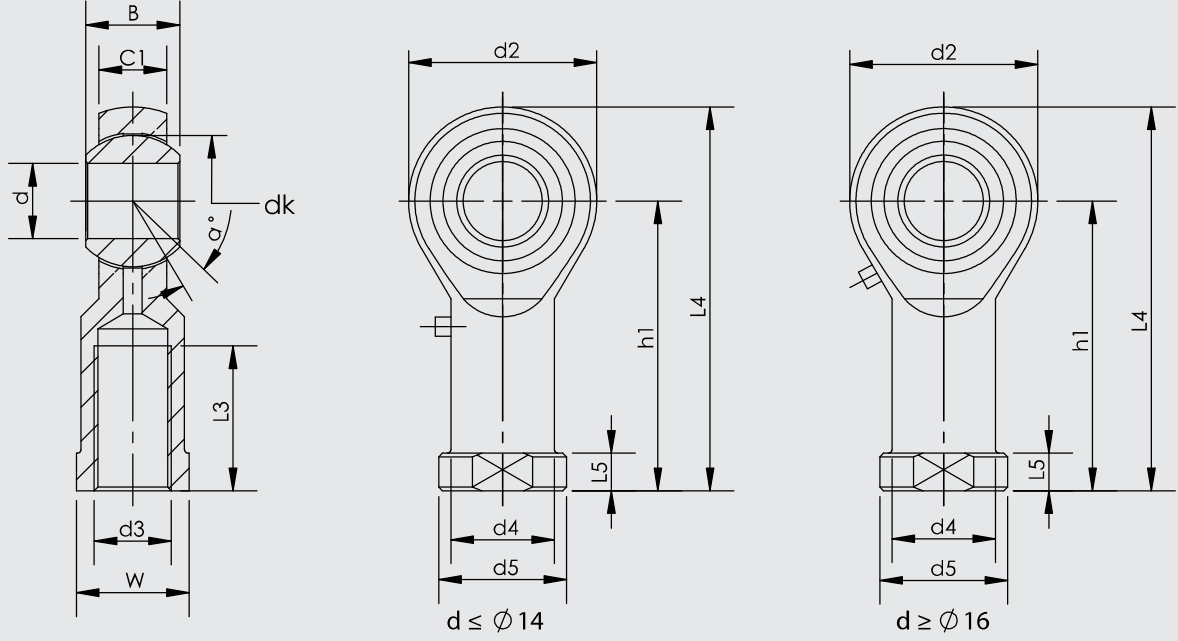

Parça No.	Ölçüler (mm)													
	d	d3 6H	B	C1	W	L3 min	d2	L4	h1	L5	d4	d5	dk	a°
KMB 10 -1	10	M10x1.25	14	10.5	17	20	26	56	43	6.5	15	19	19.05	13
KMB 12 -1	12	M12x1.25	16	12	19	22	30	65	50	6.5	17.5	22	22.225	13
KMB 16 -1	16	M16x1.5	21	15	22	28	40	84	64	8	22	27	28.575	15
KMB 20	20	M20x1.5	25	18	30	33	50	102	77	10	27.5	34	34.925	14

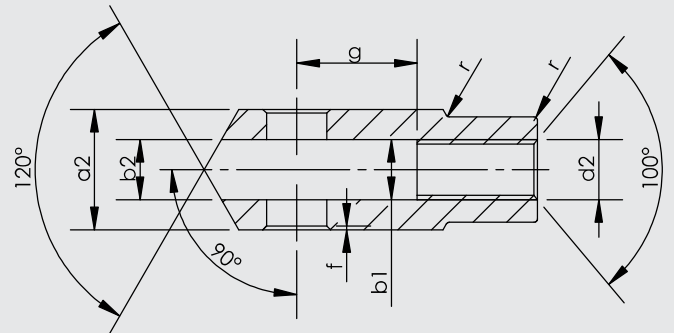
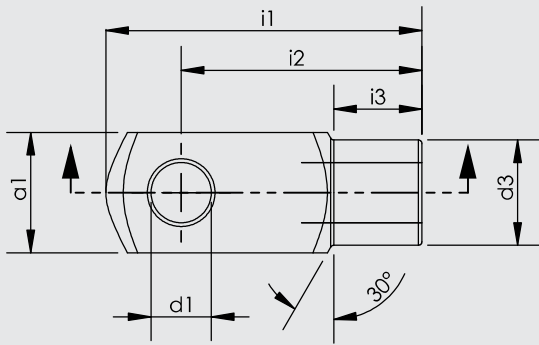

Silindir Ø mm	d1 H9	g ±0,5	a1 h 11	a2 +0,3 -0,16	b1 B 13	b2	d2 H	d3 ±0,3	f ±0,2	i1 ±0,5	i2	i3 ±0,2	r
32	10	20	20	20	10	10	M10x1.25	18	0.5	52	40	15	0.5
40	12	24	24	24	12	12	M12x1.25	20	0.5	62	48	18	0.5
50	16	32	32	32	16	16	M16x1.5	26	1	83	64	24	1
63	16	32	32	32	16	16	M16x1.5	26	1	83	64	24	1
80	20	40	40	40	20	20	M20x1.5	34	1.5	105	80	30	1.5
100	20	40	40	40	20	20	M20x1.5	34	1.5	105	80	30	1.5