

**CETOP RP 53P-43P  
PNÖMATİK SİLİNDİRLER  
PAG SERİSİ Ø32 - Ø100**



**PAG SERİSİ**

CETOP RP 43P - Ø32 - Ø100

YASTIKLAMALI SİLİNDİR

UZUN ÖMRÜ VE YÜKSEK  
 PERFORMANSIYLA 20 YILDIR  
 SANAYİNİN KÜÇÜK DEVİ.

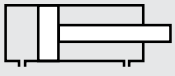
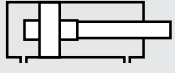
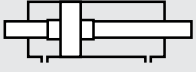
**PAG: ÇİFT ETKİLİ SİLİNDİR****PAG-Y: ÇİFT ETKİLİ  
YASTIKLAMALI SİLİNDİR****PAG-D: ÇİFT ETKİLİ  
ÇİFT MİLLİ SİLİNDİR****PAG-YD: ÇİFT ETKİLİ  
YASTIKLAMALI ÇİFT MİLLİ SİLİNDİR****Sipariş örneği:**

**PAG-Y**  
 Ürün kodu

**040-0500**  
 Silindir Ø Strok

**EB KMB**  
 Silindir  
 bağlantıları

**K1**  
 Standart dışı  
 varyasyonlar

**Standart dışı varyasyonlar:**

R1: Paslanmaz çelik silindir mili (SS 304, SS 316)

R4: Mil ucu somunu paslanmaz çelik (SS 304)

M1: Silindir milinde uzatılmış erkek diş

M2: Dişi diş açılmış silindir mili

M3: Silindir mili özel diş ölçüsü

M4: Uzatılmış silindir mili

K1: Maks. 150°C için sızdırmazlık elemanları (viton)

K2: Mil keçesi NBR+PA

K3: Sızdırmazlık elemanları NBR

K4: Mil keçesi viton

**Kuvvet değeri:**

Silindir Ø mm	Mil Ø mm	İtme ve Çekme kuvvetleri (6 Bar)	
		İtme kuvveti (N)	Çekme kuvveti (N)
32	12	482	
40	16	754	6
50	20	1178	990
63	20	1870	
80	25	30	
100	25	4712	4418

**Çalışma akışkanı:**

Filtrelenmiş ve yağlanmış hava

**Çalışma sıcaklık derecesi:**

NBR+Poliüretan (PU) : (-20°C) - (+80°C)

Viton (FKM) : (-30°C) - (+150°C)

**Maksimum çalışma basıncı:**

10 Bar

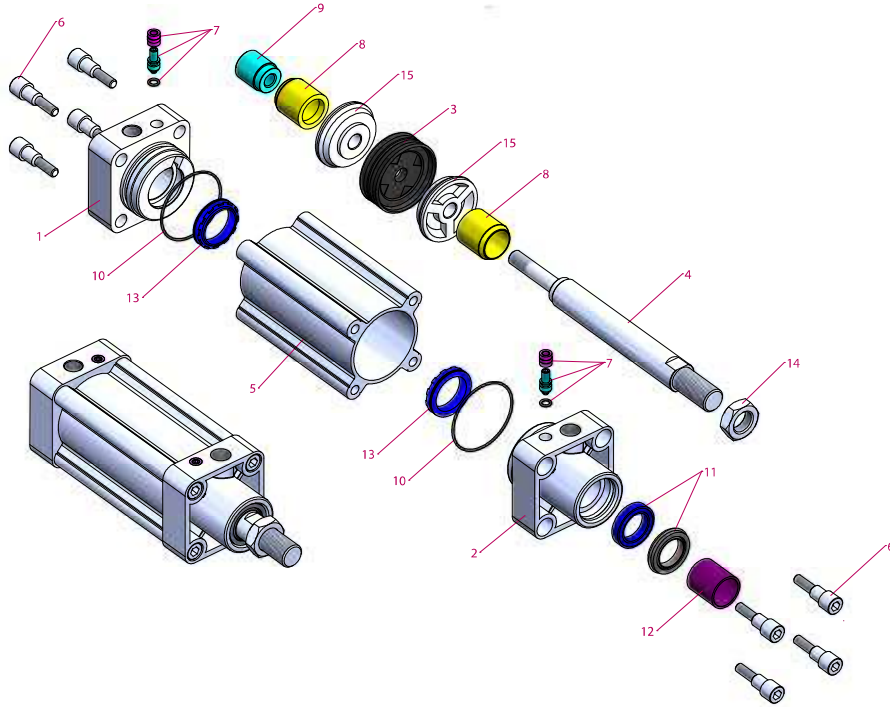
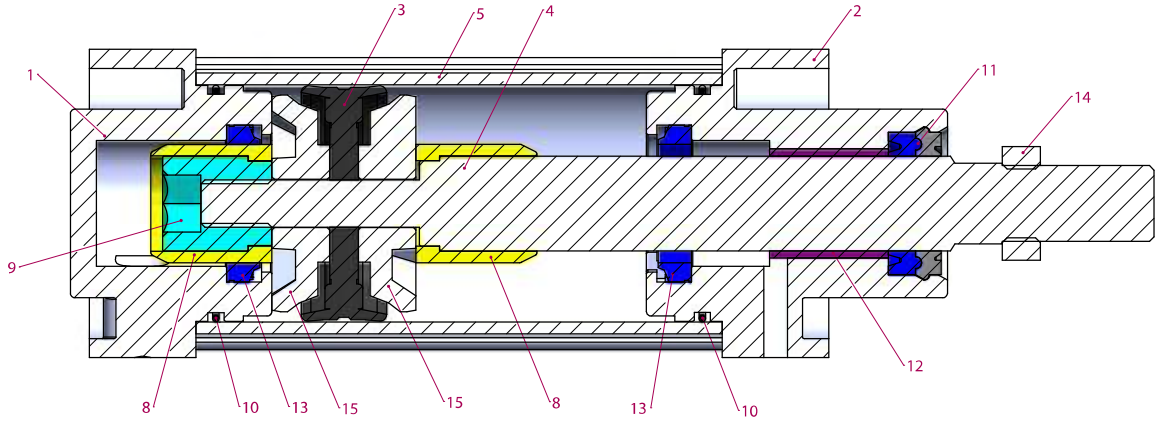

No	Malzeme adı	Malzeme özelliği	Adedi
1	Arka kapak	Alüminyum	1
2	Ön kapak	Alüminyum	1
3	Piston keçesi	NBR	1
4	Piston mili	CK45 Sert Krom kaplamalı	1
5	Boru	Al Mg Si 0,5 + Eloksal kaplamalı	1
6	Cıvata	Galvaniz kaplamalı çelik	8
7	Yastıklama vidası	Pirinç + AISI 303 NBR	2
8	Yastıklama plastiği	Polyacetal	2
9	Yastıklama dişlisi	Galvaniz kaplamalı çelik	1
10	Kapak O-ringi	NBR	2

No	Malzeme adı	Malzeme özelliği	Adedi
11	Mil keçesi	HYTREL + PU	1
12	Yataklama burcu	CSB-40	1
13	Yastıklama keçesi	PU	2
14	Somun	Galvaniz kaplamalı çelik	1
15	Piston keçesi pulu	Alüminyum	2

**Not:**

Çap 32' de yastıklama plastiği yerine yastıklama sarısı, yastıklama plastiği dişlisi yerine ise yastıklama sarısı dişlisi kullanılmaktadır. (Malzeme: Pirinç)

Silindir keçesi pulları sadece Ø32, Ø40, Ø50' de vardır. Diğer çaplarda keçe pulları yoktur.

Yastıklamasız modellerde 7, 8, 9, 13 numaralı parçalar yoktur. 9 no'lu parça yerine fiberli somun ve pulu vardır.

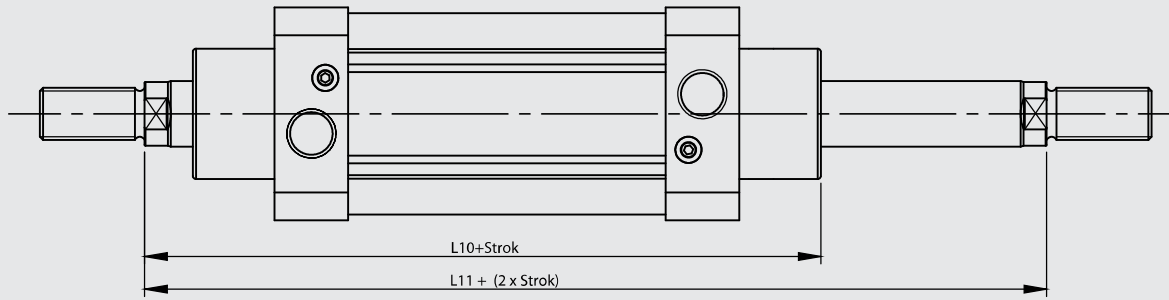
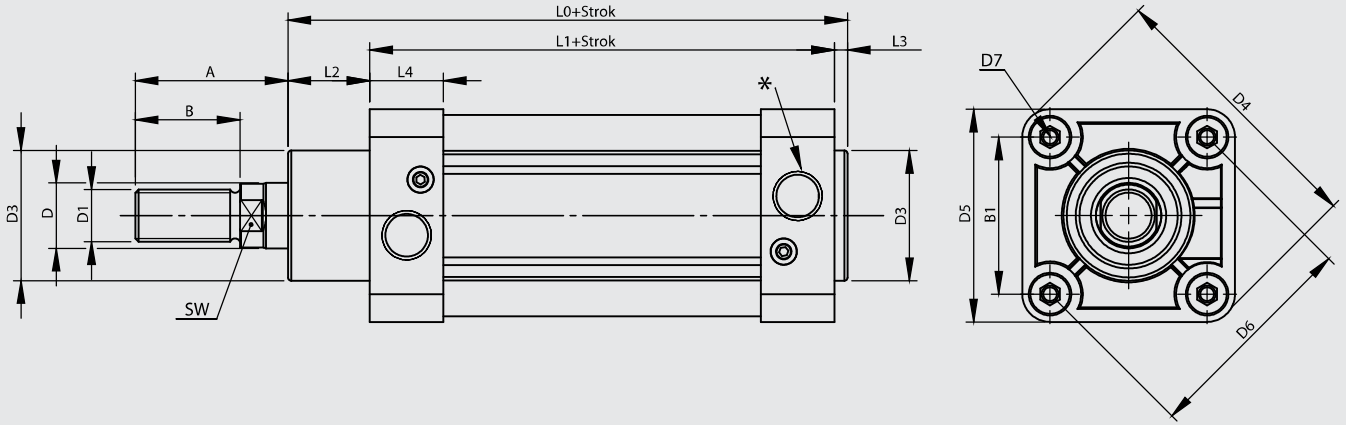

Silindir Ø mm	A	B	B1	D Ø	D1	D3 Ø	D4	D5	D6 Ø	D7	L0	L1	L2	L3	L4	L10	L11	SW	*
32	30	20	32,5	12	M10x1.25	30	58	45	46	M5	114	94	16	4	25	120	146	10	G1/8"
40	34	24	39,6	16	M12x1.25	35	71	54	56	M5	130,5	105	20	4	23	135	165	13	G1/4"
50	44	32	48	20	M16x1.5	40	85	65	68	M6	136	106	25	4	23	143	180	17	G1/4"
63	44	32	59,4	20	M16x1.5	42	105	80	84	M6	149	115	28	4	27	155	195	17	G3/8"
80	54	40	70,7	25	M20x1.5	48	125	96	100	M8	164	124	34	4	27,5	172	220	22	G3/8"
100	53	40	93,4	25	M20x1.5	52	166	126	132	M8	181	134	40	4	31,5	187	240	22	G1/2"

**FB Flaş Bağlantı**

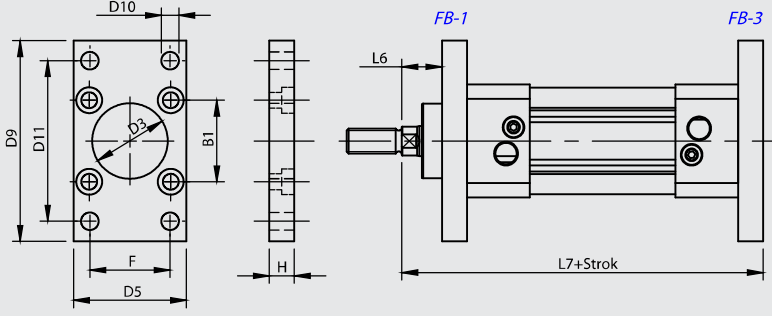

**OEB-1 Orta Eklem Bağlantılı**

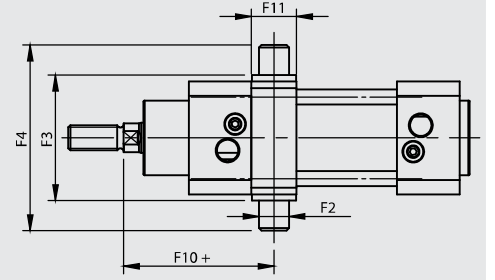

OEB-1 : Sabit Bağlantı

**AB Ayak Bağlantı**

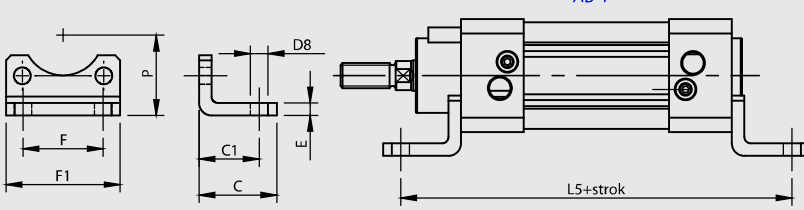

**OEB-3 Orta Eklem Bağlantı**

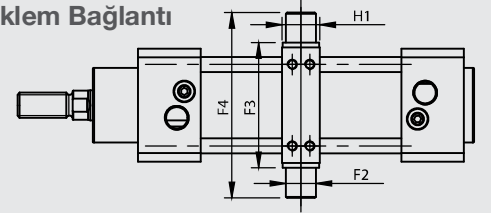

OEB-3 : Ayarlanabilir Bağlantı

**EB Eklem Bağlantı**

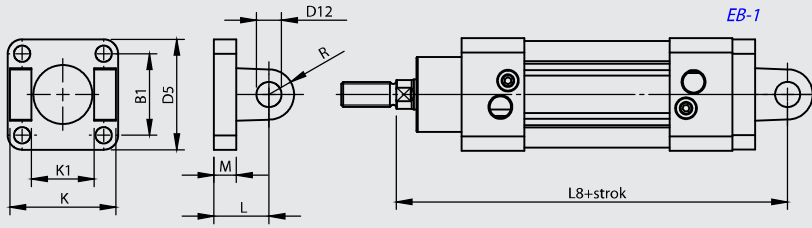

**DMB Destek Masfal Bağlantı**

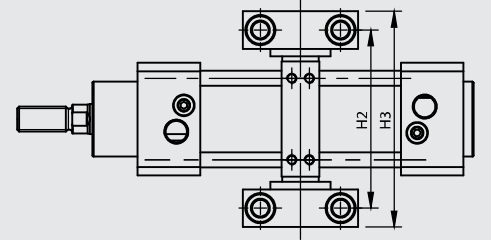

**YB Yer Bağlantı**

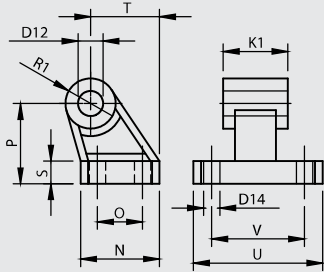

**EYB Eklem Yer Bağlantı**

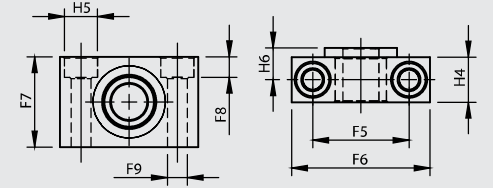
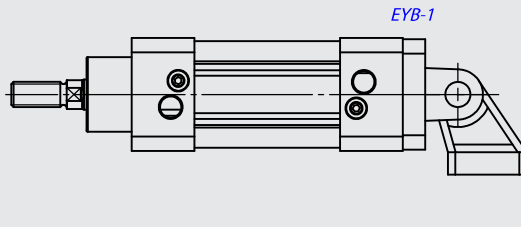

Silindir Ø mm	B1	C	C1	D3 Ø H11	D5	D8 Ø H14	D9	D10 Ø H13	D11 JS14	D12 Ø H9	D14 Ø H13	E	F	F1	F2 Ø e9	F3	F4	F5	F6	F7	F8	F9	F10	F11
32	32.5	32	24	30	45	7	77	7	64	10	6.6	4	32	45	12	50	74	32	46	30	6.8	6.6	65	21
40	39.6	38	28	35	54	9	90	9	72	12	6.6	5	36	54	16	63	95	36	55	36	9	9	69	24
50	48	42	32	40	65	9	110	9	90	12	9	6	45	65	16	75	107	36	55	36	9	9	79	
63	59.4	50	35	42	80	9	125	9	100	16	9	6	50	80	20	90	130	42	65	40	11	11	87	28
80	70.7	60	43	48	96	12	154	12	126	16	11	8	63	96	20	110	150	42	65	40	11	11	98	33
100	93.4	57	43	52	126	14	186	14	150	20	11	8	75	126	25	132	182	50	75	50	13	14	108	38

Silindir Ø mm	H	H1	H2	H3	H4	H5 Ø H13	H6	K	K1	L	L5	L6	L7	L8	M	N	O	P	R	R1	S	T	U	V
32	10	15	71	86	15	11	10.5	45	26	22	142	16	130	142	8	31	18	32	10	10	8	27.5	51	38
40	10	20	87	105	18	15	12	52	28	25	161	20	145	160	9	35	22	36	13	11	10	30.5	54	41
50	12	20	99	117	18	15	12	60	32	27	170	25	155	170	11	45	30	45	16	13	12	40.5	65	50
63	15	25	116	136	20	18	13	70	40	35	185	25	170	190	12	50	35	50	18	15	12	44.5	67	52
80	18	25	136	156	20	18	13	90	50	38	210	30	190	210	14	60	40	63	18	15	14	57	86	
100	18	30	164	189	24.5	20	16	110	60	43	220	35	205	230	15	70	50	71	23	19	15	65	96	76

## FB Flanş Bağlantı

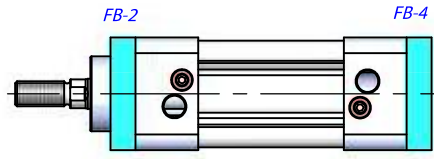
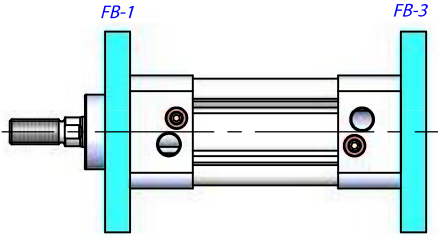

## AB Ayak Bağlantı

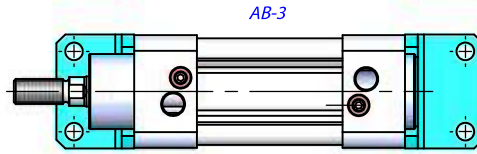
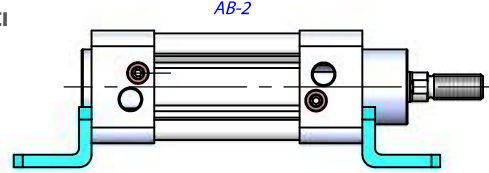
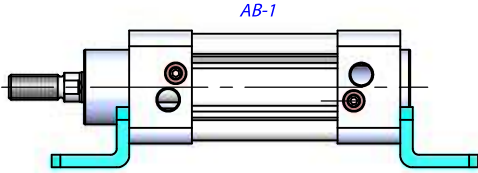

## EB Ekleme Bağlantı

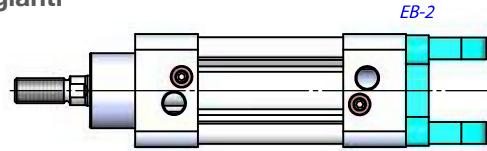
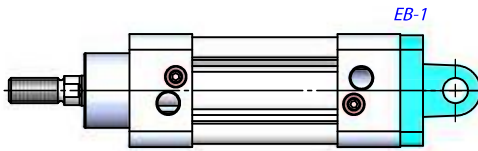

## EYB Ekleme Yer Bağlantı

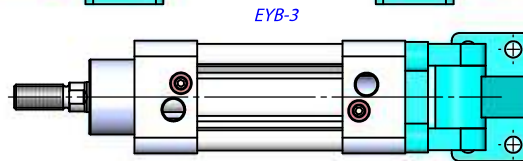
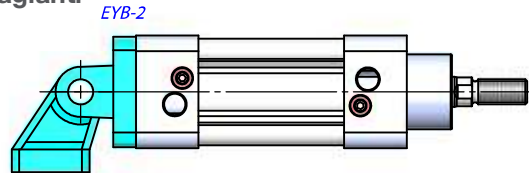
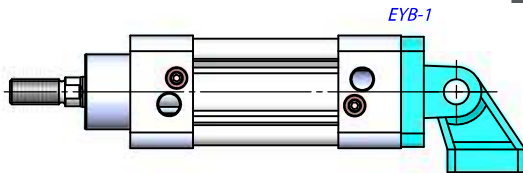

## OEB Orta Ekleme Bağlantı

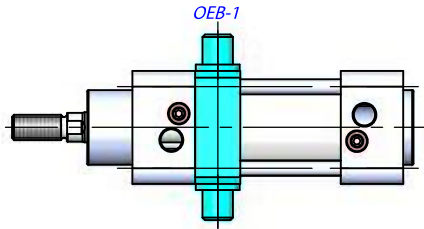
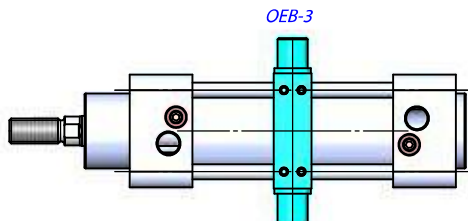
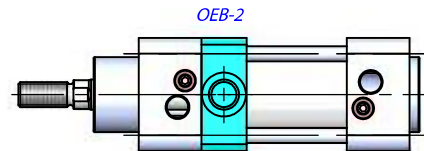
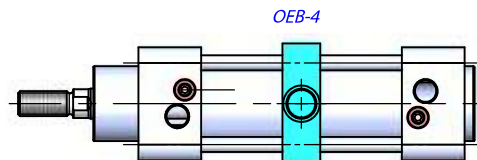
OEB-1-2  
Sabit BağlantıOEB-3-4  
Ayarlanabilir Bağlantı

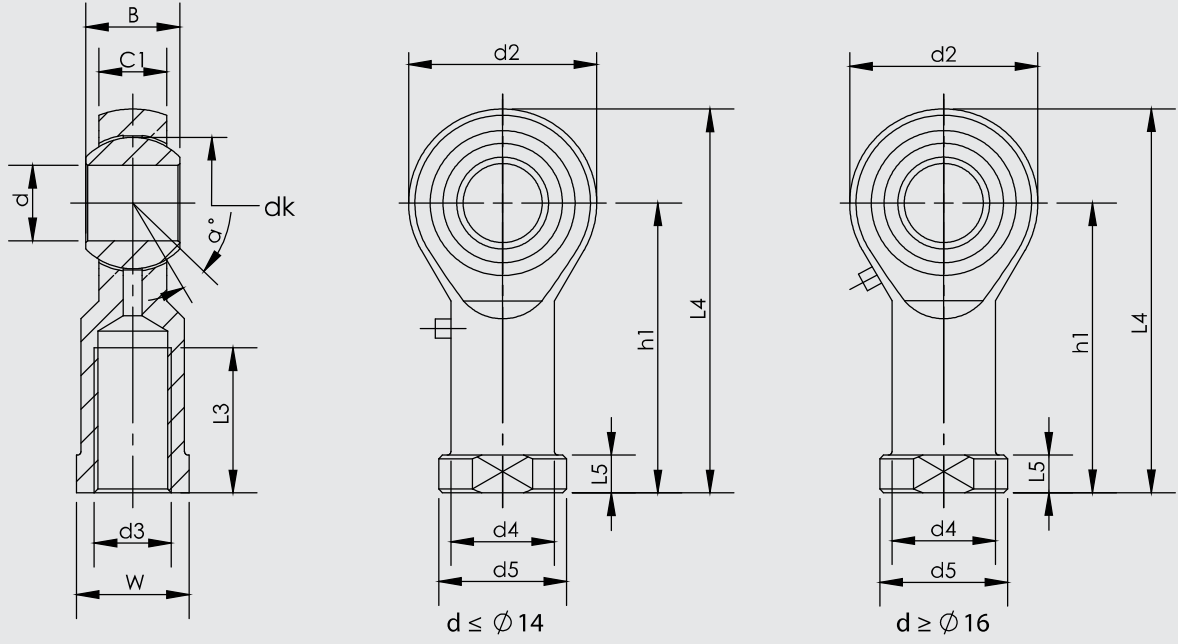

Ölçüler (mm)

Parça No.	Ölçüler (mm)													
	d	d3 6H	B	C1	W	L3 min	d2	L4	h1	L5	d4	d5	dk	a°
KMB 10 -1	10	M10x1.25	14	10.5	17	20	26	56	43	6.5	15	19	19.05	13
KMB 12 -1	12	M12x1.25	16	12	19	22	30	65	50	6.5	17.5	22	22.225	13
KMB 16 -1	16	M16x1.5	21	15	22	28	40	84	64	8	22	27	28.575	15
KMB 20	20	M20x1.5	25	18	30	33	50	102	77	10	27.5	34	34.925	14

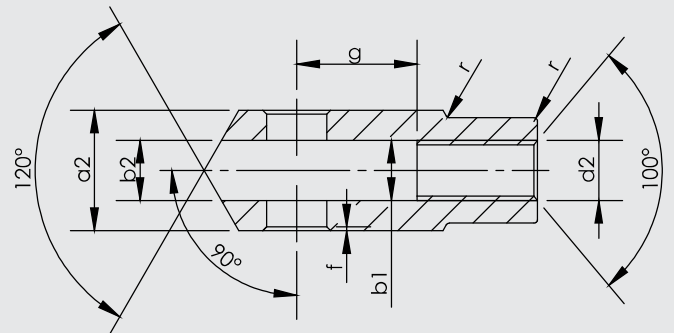
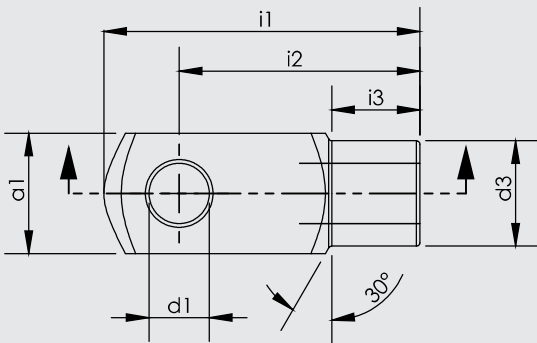

Silindir Ø mm	d1 H9	g ±0,5	a1 h 11	a2 <sup>+0,3</sup> -0,16	b1 B 13	b2	d2 H	d3 ±0,3	f ±0,2	i1 ±0,5	i2	i3 ±0,2	r
32	10	20	20	20	10	10	M10x1.25	18	0.5	52	40	15	0.5
40	12	24	24	24	12	12	M12x1.25	20	0.5	62	48	18	0.5
50	16	32	32	32	16	16	M16x1.5	26	1	83	64	24	1
63	16	32	32	32	16	16	M16x1.5	26	1	83	64	24	1
80	20	40	40	40	20	20	M20x1.5	34	1.5	105	80	30	1.5
100	20	40	40	40	20	20	M20x1.5	34	1.5	105	80	30	1.5