

**KOMPAKT
PNÖMATİK SİLİNDİRLER
PK-A SERİSİ Ø32- Ø100**





PK-A SERİSİ

KOMPAKT - Ø32 - Ø100

KOMPAKT
MANYETİK SİLİNDİR

DAHA KÜÇÜK ALANDA DAHA
YÜKSEK GÜÇ İÇİN DOĞRU SEÇİM.

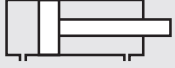

PK: KOMPAKT,
ÇİFT ETKİLİ SİLİNDİR



PK-A: KOMPAKT MANYETİK,
ÇİFT ETKİLİ SİLİNDİR

Sipariş örneği:

PK-A
Ürün kodu

032-025
Silindir Ø Strok

K1 M1
Standart dışı varyasyonlar

Standart dışı varyasyonlar:

- R1: Paslanmaz çelik silindir mili (SS 304, SS 316)
- R4: Mil ucu somunu paslanmaz çelik (SS 304)
- R5: Silindir mili CK 45 çelik (sert krom kaplı)
- M1: Silindir milinde uzatılmış erkek diş
- M3: Silindir mili özel diş ölçüsü
- M4: Uzatılmış silindir mili
- K1: Maks. 150°C için sızdırmazlık elemanları (viton)
- K4: Mil keçesi viton

Kuvvet değeri:

Silindir Ø mm	Mil Ø mm	İtme ve Çekme kuvvetleri (6 Bar)	
		İtme kuvveti (N)	Çekme kuvveti (N)
32	12	482	415
40	12	754	687
50	16	1178	1058
63	16	1869	1750
80	20	3014	
100	25	4710	4420

Çalışma akışkanı:

Filtrelenmiş ve yağlanmış ya da filtrelenmiş ve yağsız hava

Çalışma sıcaklık derecesi:

Poliüretan (PU) : (-20°C) - (+80°C)
Viton (FKM) : (-30°C) - (+180°C)

Maksimum çalışma basıncı:

10 Bar

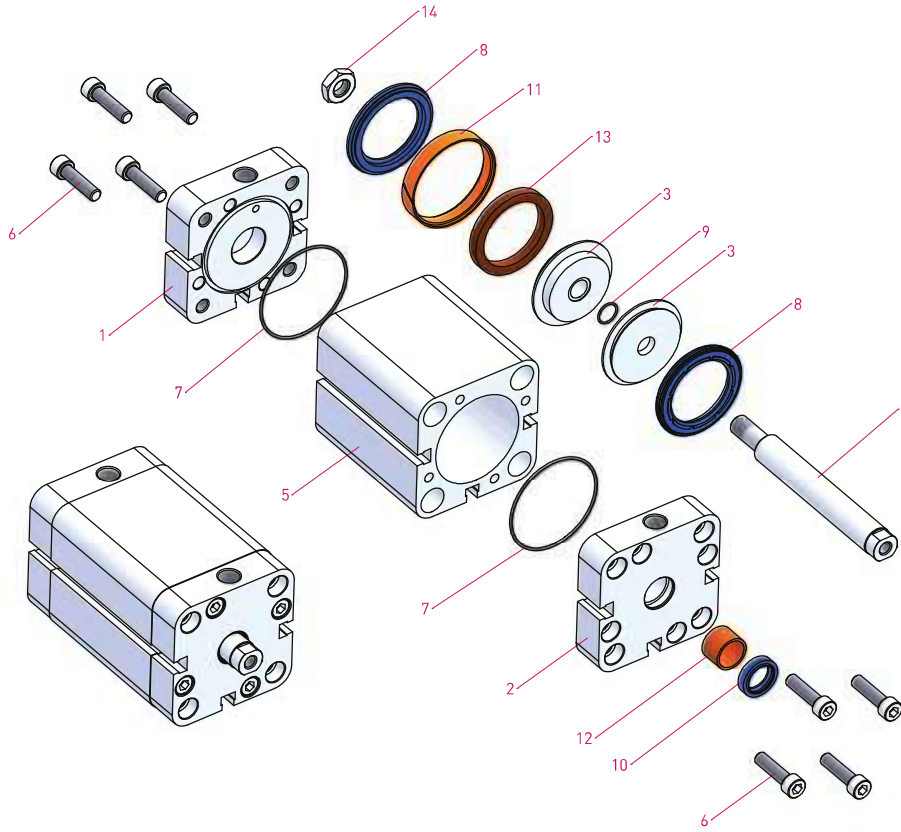
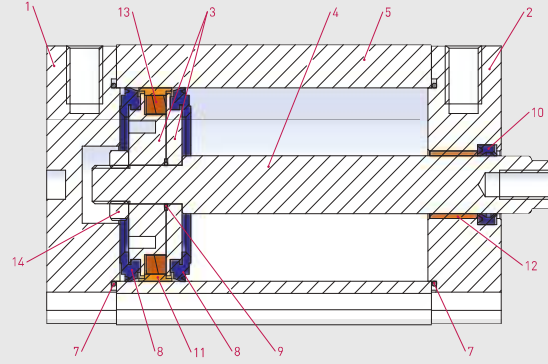

No	Malzeme adı	Malzeme özelliği	Adedi
1	Arka Kapak	Alüminyum	1
2	Ön Kapak	Alüminyum	1
3	Orta Piston	Alüminyuma	2
4	Piston Mili	X20 Cr13 Sert Krom Kaplamalı	1
5	Boru	AlMgSi0. +Eloksal Kaplamalı	1
6	Civata	Paslanmaz Çelik	8
7	Kapak O-ringi	NBR	2

No	Malzeme adı	Malzeme özelliği	Adedi
8	Piston Keçesi	PU	2
9	Orta Piston O-ringi	NBR	1
10	Mil Keçesi	PU	1
11	Yataklama Bandı	Polyacetal	1
12	Yataklama Burcu	CSB-40	1
13	Mıknatıs		1
14	Somun	Galvaniz Kaplamalı Çelik	1



PK-A SERİSİ
 KOMPAKT - Ø32 - Ø100

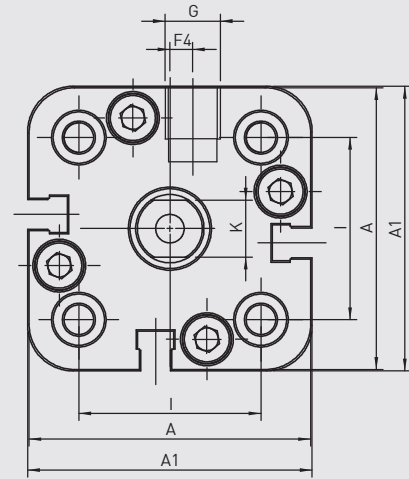
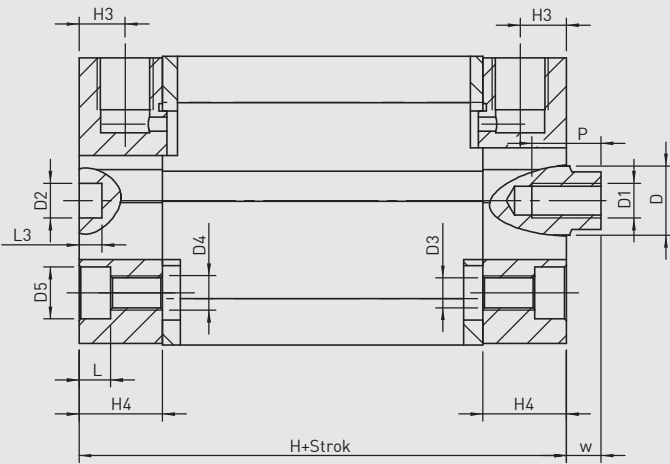

Silindir Ø mm	A	A1	D Ø	D1 Ø	D2 Ø	D3 Ø	D4 Ø	D5 Ø	F4	G	H	H3	H4	I	K	L	L3	P	W
32	49,5	50	12	M6	6	5,2	M6	9	4	1/8"	44,5	8	14,5	32	10	5,5	4	1	
40	57,5	58	12	M6	6	5,2	M6	9	3	1/8"	45,5	8	14,75	42	10	5,5	4	12	6,5
50	66,5	67	16	M8	6	6,7	M8	10,5	0	1/8"	45,5	8	14,75	50	13	6,5	4	12	7,5
63	79,5	80	16	M8	8	8,7	M10	13,5	0	1/8"	50	8	14,75	62	13	8,5	4	14	
80	99,5	100	20	M10	8	8,7	M10	13,5	0	1/8"	56	8,5	16,5	82	17	8,5	4	15	8
100	123,5	124	25	M12	8	8,7	M10	13,5	0	1/4"	66,5	10,5	19,75	103	22	8,5	4	20	10



PK-T

PKS-T

PKE-T

PKD-T

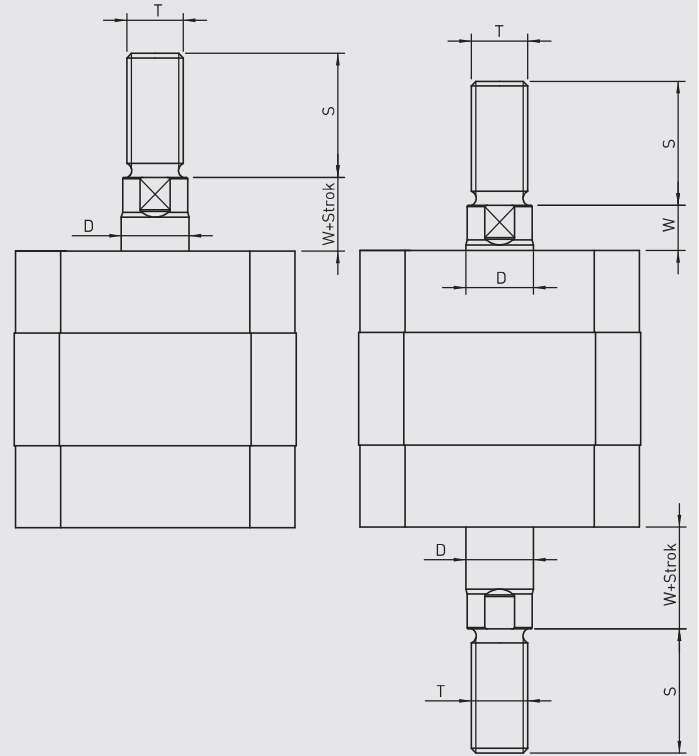
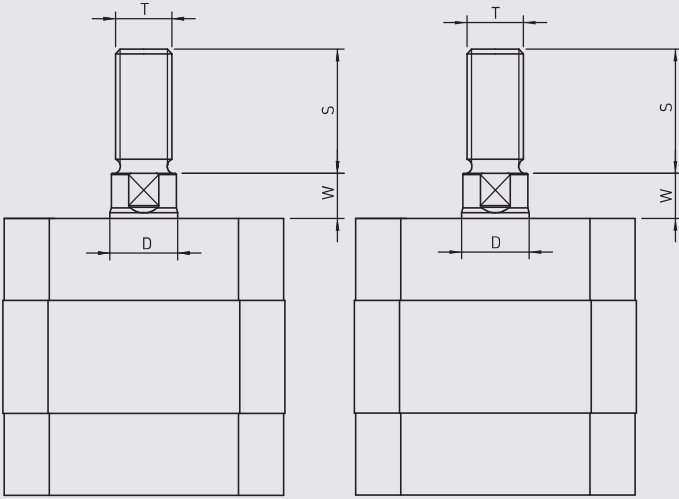

Silindir tipi	Silindir Ø mm	D	S	T	W
	32	12	22	M10x1.25	
	40	12	22	M10x1.25	6.
PK-PKS	50	16	24	M12x1.25	7.5
PKE-PKD	63	16	24	M12x1.25	7.
	80	20	32	M16x1.5	8
	100	25	40	M20x1.5	10