

ISO 15552  
PNÖMATİK SİLİNDİRLER  
PMB SERİSİ Ø125 - Ø320

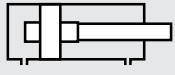
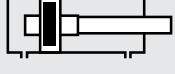

**PMB SERİSİ**

ISO 15552 - Ø125 - Ø320

ALÜMİNYUM BORULU  
MANYETİK YASTIKLAMALI SİLİNDİRGÜÇLÜ GÖVDE YAPISI İLE  
EN ZOR ORTAMLARDA BİLE  
YÜKSEK PERFORMANS.**PMB:** ÇİFT ETKİLİ SİLİNDİR**PMB-Y:** ÇİFT ETKİLİ  
YASTIKLAMALI SİLİNDİR**PMB-A:** ÇİFT ETKİLİ  
MANYETİK SİLİNDİR**PMB-D:** ÇİFT ETKİLİ  
ÇİFT MİLLİ SİLİNDİR**PMB-YA:** ÇİFT ETKİLİ  
YASTIKLAMALI MANYETİK SİLİNDİR**PMB-YD:** ÇİFT ETKİLİ  
YASTIKLAMALI ÇİFT MİLLİ SİLİNDİR**PMB-AD:** ÇİFT ETKİLİ  
MANYETİK ÇİFT MİLLİ SİLİNDİR**Sipariş örneği:****PMB-YA**

Ürün kodu

**160-0200**

Silindir Ø Strok

**EB ÇB**Silindir  
bağlantıları**K1**Standart dışı  
varyasyonlar**Standart dışı varyasyonlar:**

- R1: Paslanmaz çelik silindir mili (SS 304, SS 316)
- R2: Paslanmaz çelik saplamalar (SS 304, SS 316)
- R3: Kapak bağlantı civataları paslanmaz çelik (SS 304)
- R4: Mil ucu somunu paslanmaz çelik (SS 304)
- R5: Silindir mili CK 45 çelik (sert krom kaplamalı)
- M1: Silindir milinde uzatılmış erkek diş
- M2: Dişi diş açılmış silindir mili
- M3: Silindir mili özel diş ölçüsü
- M4: Uzatılmış silindir mili
- K1: Maks. 150°C için sızdırmazlık elemanları (viton)
- K2: Mil keçesi NBR+PA
- K3: Sızdırmazlık elemanları NBR
- K4: Mil keçesi viton

**Çalışma akışkanı:**

Filtrelenmiş ve yağlanmış ya da filtrelenmiş ve yağsız hava

**Çalışma sıcaklık derecesi:**

Poliüretan (PU) : (-20°C) - (+80°C)  
 Viton (FKM) : (-30°C) - (+150°C)

**Maksimum çalışma basıncı:**

10 Bar

**Kuvvet değeri:**

Silindir Ø mm	Mil Ø mm	İtme ve Çekme kuvvetleri (6 Bar)	
		İtme kuvveti (N)	Çekme kuvveti (N)
125	32	7360	6880
160	40	12064	11310
200	40	18850	18096
250	50	29450	2827
320	63	48250	46380

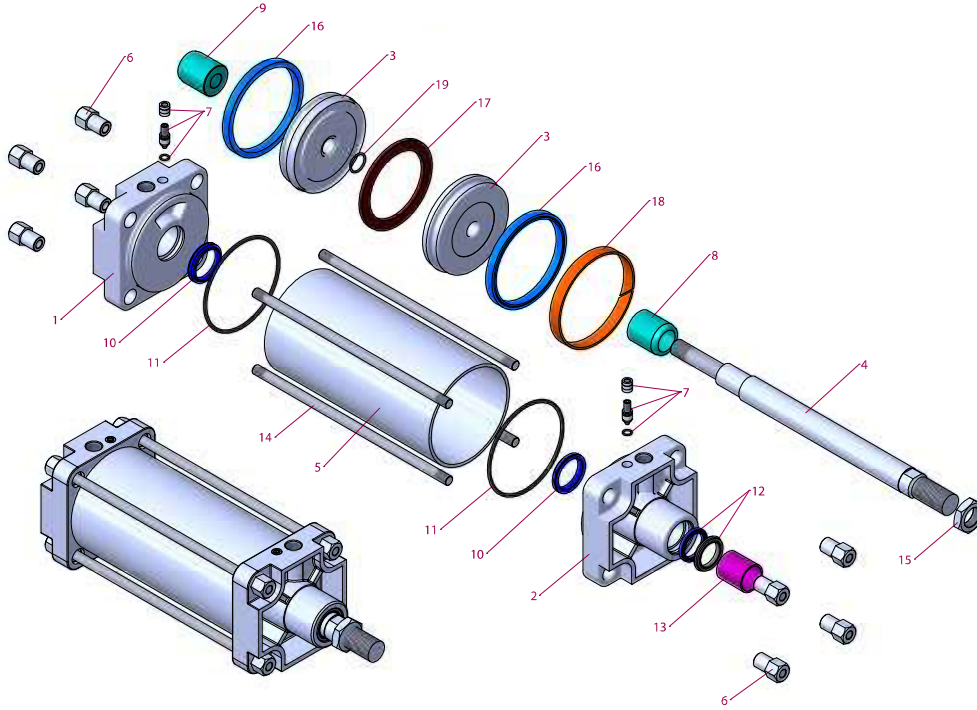
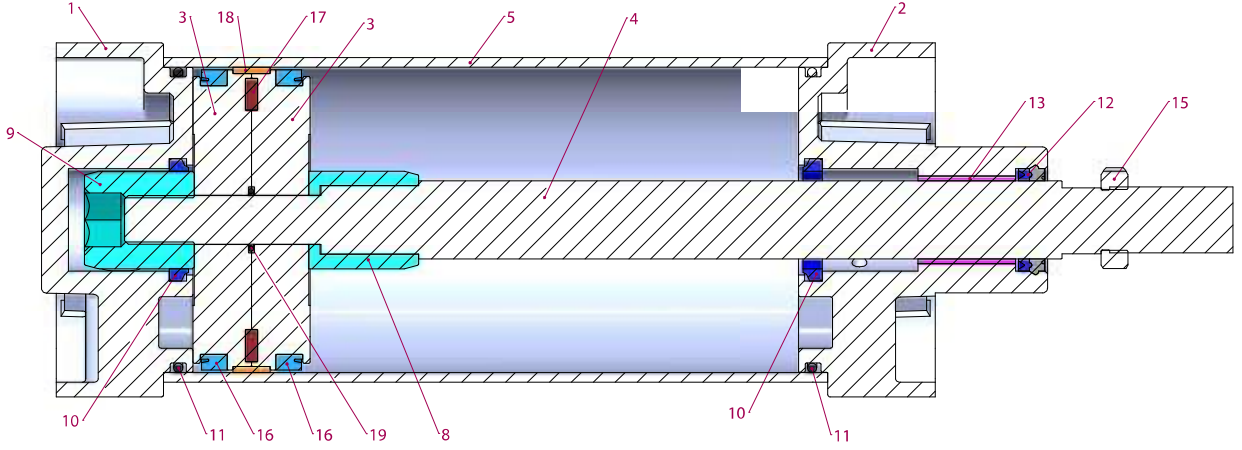

No	Malzeme adı	Malzeme özelliği	Adedi
1	Arka kapak	Alüminyum	1
2	Ön kapak	Alüminyum	1
3	Orta piston	Alüminyum	2
4	Piston mili	X20 Cr13 Sert Krom kaplamalı	1
5	Boru	Al Mg Si 0,5 + Eloksal kaplamalı	1
6	T-somun	Galvaniz kaplamalı çelik	8
7	Yastıklama vidası	Pirinç+ AISI 303 NBR	2
8	Yastıklama borusu	Alüminyum	1
9	Yastıklama dişlisi	Alüminyum	1
10	Yastıklama keçesi	PU	2
11	Kapak O-ringi	NBR	2

No	Malzeme adı	Malzeme özelliği	Adedi
12	Mil keçesi	HYTREL + PU	1
13	Yataklama burcu	CSB-40	1
14	Saplama	Galvaniz kaplamalı çelik	4
15	Somun	Galvaniz kaplamalı çelik	1
16	Piston keçesi	PU	2
17	Mıknatis		1
18	Yataklama bandı	Polyasetal	1
19	Orta piston O-ringi	NBR	1

**Not:**

Yastıklamasız modellerde 7, 8, 9, 10 numaralı parçalar yoktur.

9 no'lu parça yerine fiberli somun ve pulu vardır.

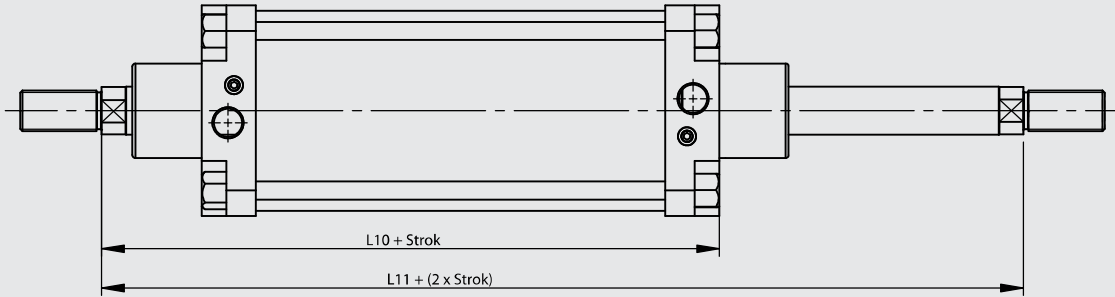
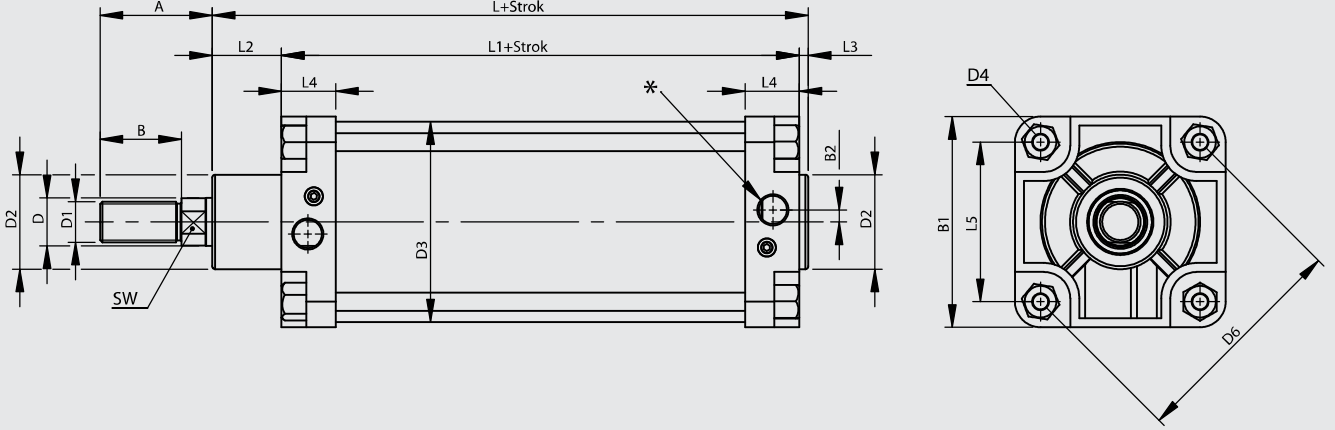

Silindir Ø mm	A	B	B1	B2	D Ø	D1	D2 Ø	D3 Ø	D4	D6 Ø	L	L1	L2	L3	L4	L5	L10	L11	SW	*
125	73	54	145	11.5	32	M27x2	60	133	M12	155.5	213	160	46	6	44	110	225	290	27	G1/2"
160	97	72	186	13.5	40	M36x2	65	170	M16	198	243	180	55	6	47	140	260	340	36	G3/4"
200	102	72	220	13.5	40	M36x2	75	210	M16	247.5	253	180	65	6	47	175	275	370	36	G3/4"
250	122	84	270	14	50	M42x2	90	262	M20	311.1	281	200	69	10	51	220	305	410	46	G1"
320	134	96	340	20	63	M48x2	110	336	M24	381.8	314	220	82	10	56	270	340	460	55	G1"

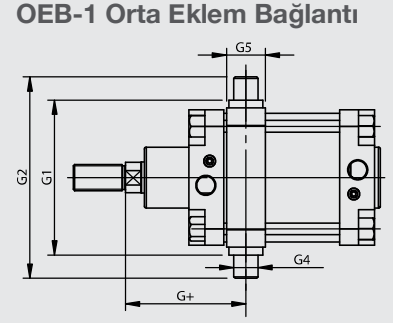
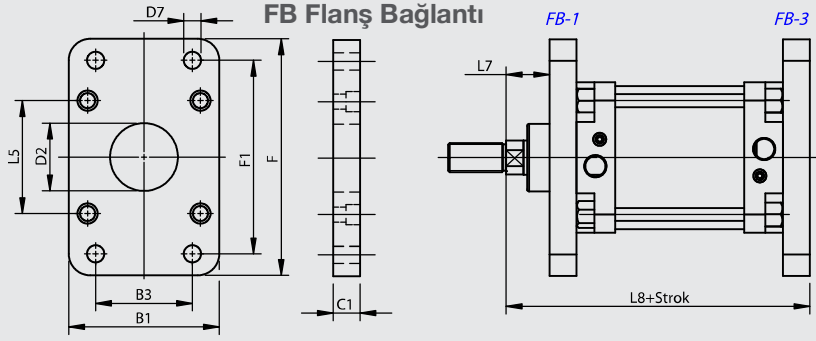

OEB-1 : Sabit Bağlantı

**AB Ayak Bağlantı**

AB-1

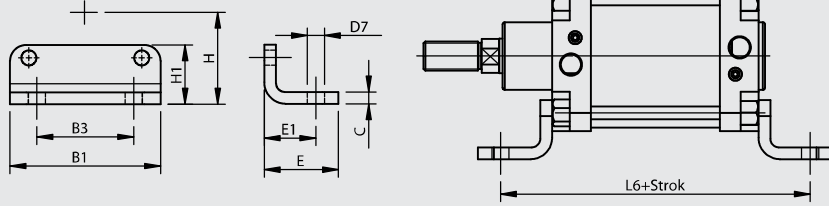

**OEB-3 Orta Eklem Bağlantı**

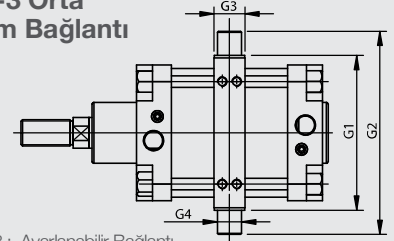

OEB-3 : Ayarlanabilir Bağlantı

**EB Eklem Bağlantı**

EB-1

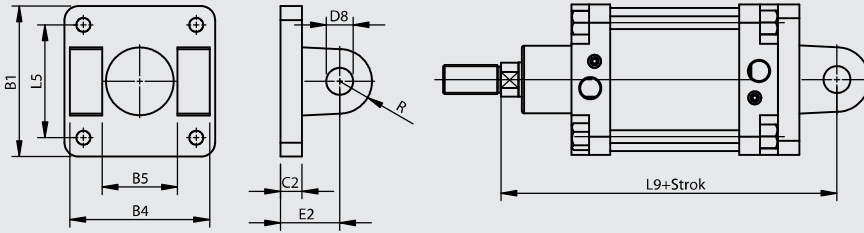

**DMB Destek Masfal Bağlantı**

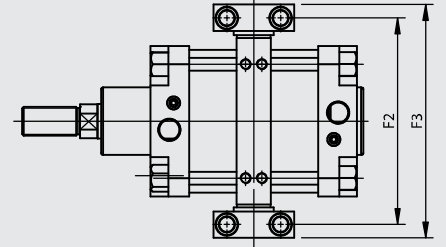

**YB Yer Bağlantı**

**EYB Eklem Yer Bağlantı**

EYB-1

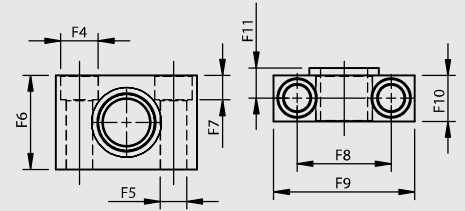
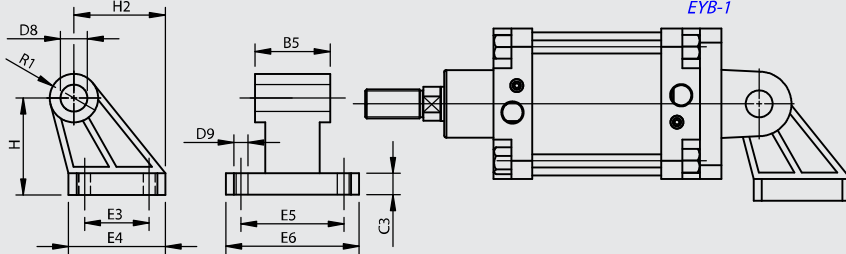

Silindir Ø mm	B1	B3	B4	B5	C	C1	C2	C3	D2 Ø	D7 Ø	D8 Ø	D9 Ø	E	E1	E2	E3	E4	E5	E6	F	F1	F2	F3	F4
		JS14	h14	H14					H11	H13	H9	H13				JS14		JS14		JS14				H13
125	145	90	130	70	8	20	20	20	60	16	25	14	67	45	50	60	90	94	124	220	180	192	217	20
160	186	115	170	90	9	20	20	25	65	18	30	14	87	60	55	88	126	118	156	280	230	245	280	26
200	220	135	170	90	12	25	25	30	75	22	30	18	95	70	60	90	130	122	162	320	270	295	330	2
250	270	165	200	110	20	25	25	35	90	26	40	22	105	75	70	110	160	150	200	390	330	375	420	
320	340	200	220	120	23	30	30	40	110	33	45	26	125	85	80	122	186	170	234	470	400	465	520	

Silindir Ø mm	F5 Ø	F6	F7	F8	F9	F10	F11	G1	G2	G3	G4 Ø	G5	G+	H	H1	H2	L5	L6	L7	L8	L9	R	R1
	H13			±0,3				h14			e9			JS16									
125	14	50	13	50	75	24.5	16	160	210	32	25	38	128	90	55	85	110	250	45	245	275	30	22.5
160	18	60	17	60	92	36	22.5	200	264	40	32	48	151	115	70	116	140	300	60	280	315	32	31.5
200	18	60	17	60	92	36	22.5	250	314	40	32	48	166	135	80	125	175	320	70	300	335	35	31.5
250	22	70	21.5	90	140	45	27.5	320	400	50	40	60	189	165	100	153	220	350	80	330	375	45	40
320	26	80	25.5	100	150	55	32.5	400	500	60	50	65	210	200	120	182	270	390	90	370	420	54	45

FB-1

FB-3

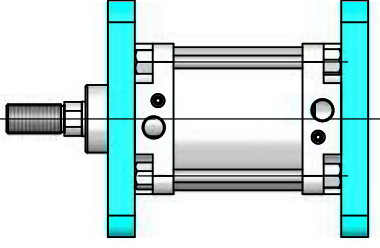
**FB Flanş Bağlantı**

FB-2

FB-4

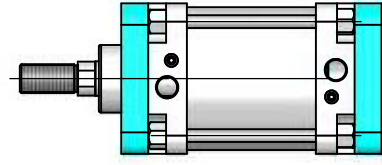
**AB Ayak Bağlantı**

AB-1

AB-3

AB-2

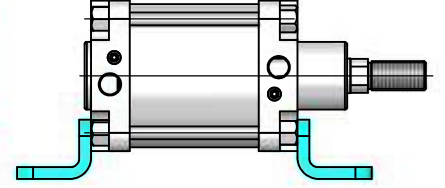
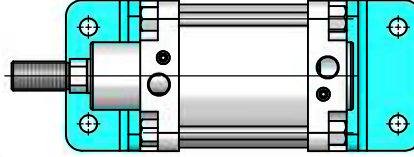
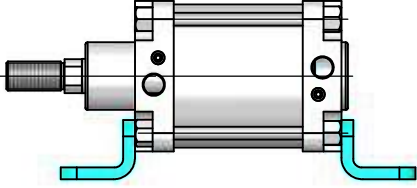
**EB Ekleme Bağlantı**

EB-1

EB-2

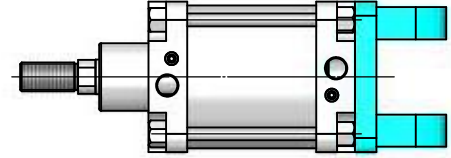
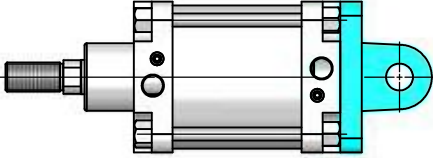
**EYB Ekleme Yer Bağlantı**

EYB-1

EYB-2

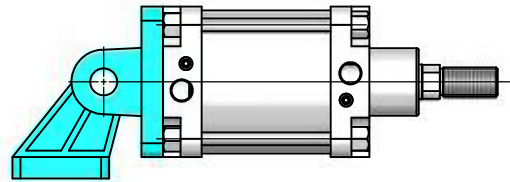
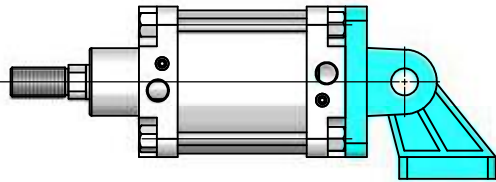

EYB-3

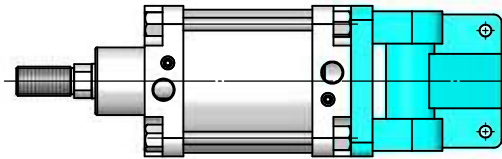
**OEB Orta Ekleme Bağlantı**

OEB-1

OEB-2

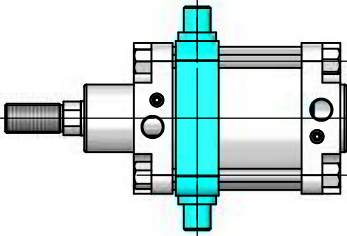

OEB-1-2 Sabit Bağlantı

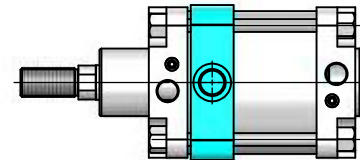

OEB-3

OEB-4

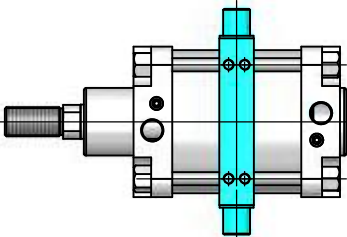

OEB-3-4 Ayarlanabilir Bağlantı

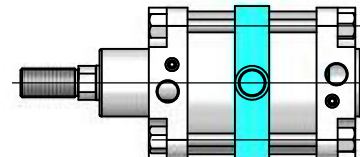

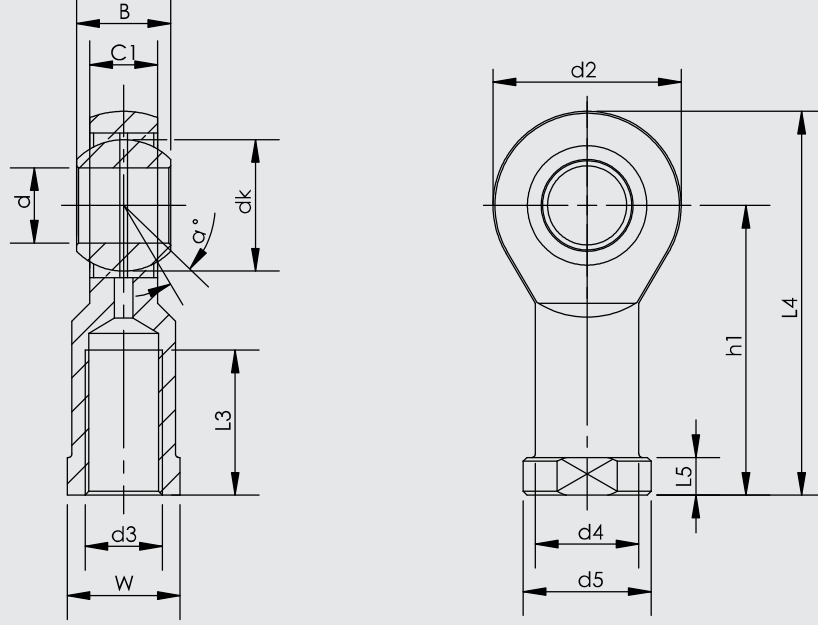

Parça No.	Ölçüler (mm)													
	d	d3 6H	B	C1	W	L3 min	d2	L4	h1	L5	d4	d5	dk	α°
KMB 28	28	M27x2.0	35	24	41	48	66	136	103	14	37	46	47.6	15
KMB 30-1	30	M27x2.0	37	25	41	51	70	145	110	15	40	50	50.8	17
KMB 30	30	M30x2.0	37	25	41	51	70	145	110	15	40	50	50.8	17
KMB 35	35	M36x2.0	43	28	50	56	81	165.5	125	17	46	58	57.1	16
KMB 35 UK	35	M36x3.0	25	21	50	60	82	166	125	15	47	58	47	6
KMB 40 UK	40	M39x3.0	28	23	55	65	92	188	142	18	52	65	53	7
KMB 40	40	M42x2.0	49	33	55	60	91	187.5	142	19	53	65	66.6	17
KMB 50 UK	50	M45x3.0	35	30	65	68	112	216	160	20	62	75	66	6
KMB 50	50	M48x2.0	60	45	65	65	117	218.5	160	23	65	75	82.5	12

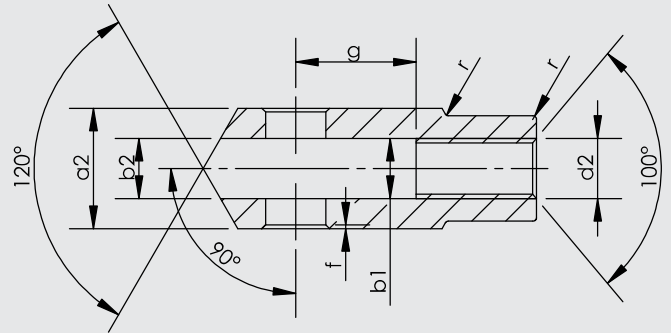
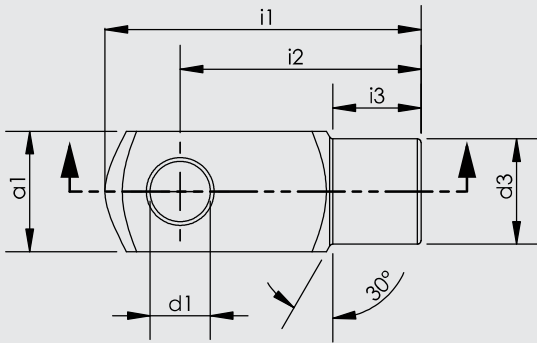

Silindir Ø mm	d1 H9	g ±0,5	a1 h 11	a2 +0,3 -0,16	b1 B 13	b2	d2 6H	d3 ±0,3	f ±0,2	i1 ±0,5	i2	i3 ±0,2	r
125	25	50	50	50	25	25	M27x2	42	1.5	132	100	36	1.5
160	35	72	70	70	35	35	M36x2	60	2	188	144	41	2
200	35	72	70	70	35	35	M36x2	60	2	188	144	41	2
250	40	96	80	80	40	40	M42x2	70	3	220	168	43	3
320	50	111	90	90	50	50	M48x2	80	3	250	192	44	3

PMB Ø 125

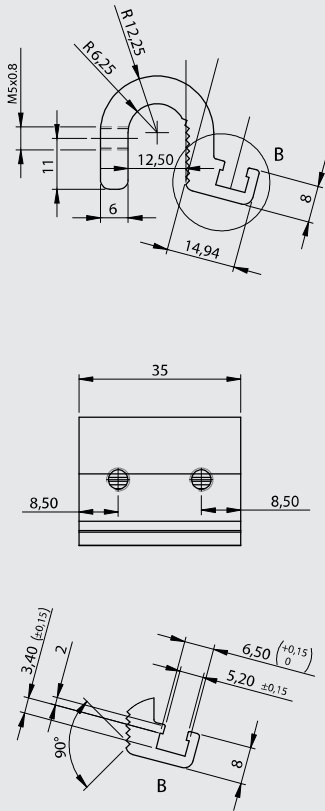

PMB Ø 160

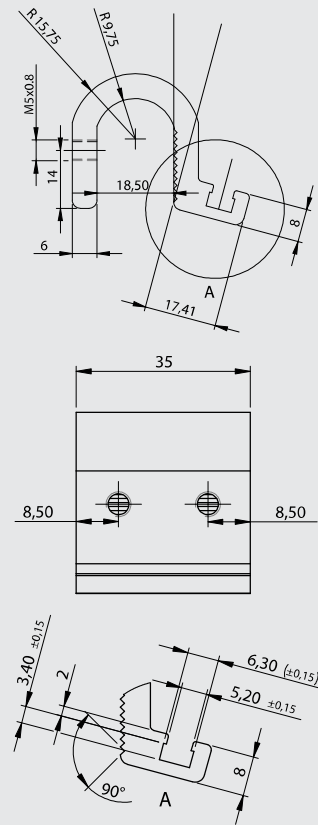

PMB Ø 200

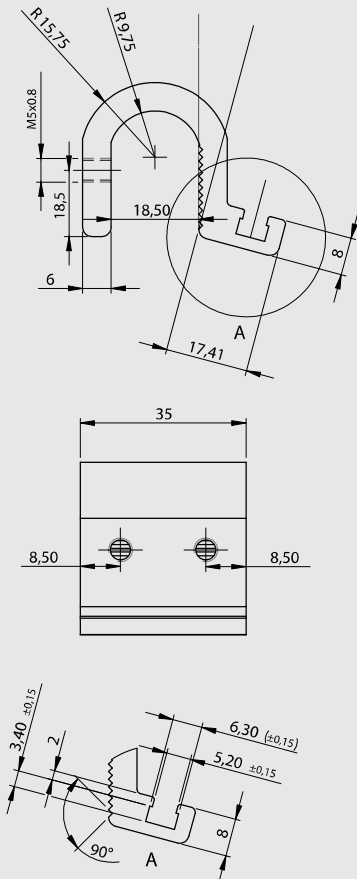

PMB Ø 250 - Ø 320

