

ISO 6432
PNÖMATİK SİLİNDİRLER
PMY-A SERİSİ Ø16 - Ø25





PMY-A SERİSİ

ISO 6432 - Ø16 - Ø25

ÇİFT ETKİLİ
MANYETİK YASTIKLAMALI SİLİNDİR

PASLANMAZ ÇELİK MİL VE
BORULARIYLA MAKSİMUM ÇALIŞMA
HIZI SAĞLAR.

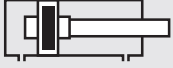

**PMY-A: ÇİFT ETKİLİ
MANYETİK YASTIKLAMALI
SİLİNDİR**

Sipariş örneği:

PMY-A

Ürün kodu

25-050

Silindir Ø Strok

EB KMB

Silindir
bağlantıları

R1 K4

Standart dışı
varyasyonlar

Standart dışı varyasyonlar:

- R1: Paslanmaz çelik silindir mili (SS 304, SS 316)
- R4: Mil ucu somunu paslanmaz çelik (SS 304)
- R5: Silindir mili CK45 çelik (sert krom kaplı)
- M1: Silindir milinde uzatılmış erkek diş
- M2: Dişi diş açılmış silindir mili
- M3: Silindir mili özel diş ölçüsü
- M4: Uzatılmış silindir mili
- E2: Kapaklar paslanmaz çelik (SS 304-SS316)
- K1: Maks. 150°C için sızdırmazlık elemanları (viton)
- K3: Sızdırmazlık elemanları NBR
- K4: Mil keçesi viton

Çalışma akışkanı:

Filtrelenmiş ve yağlanmış ya da filtrelenmiş ve yağsız hava

Çalışma sıcaklık derecesi:

Poliüretan (PU) : (-20°C) - (+80°C)
Viton (FKM) : (-30°C) - (+180°C)

Maksimum çalışma basıncı:

10 Bar

Kuvvet değeri:

Silindir Ø mm	Mil Ø mm	İtme ve Çekme kuvvetleri (6 Bar)	
		İtme kuvveti (N)	Çekme kuvveti (N)
16	6	105	
20	8	165	14
25	10	266	219

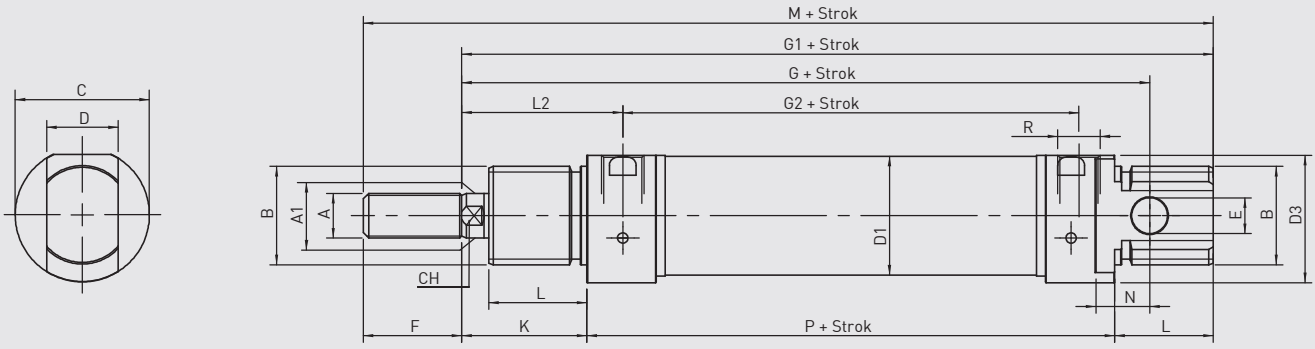

PMY-A SERİSİ
 ISO 6432 - Ø16 - Ø25

Silindir Ø mm	A	A1	B	C	D	D1	D3	E	F	G	G1	G2	K	L	L2	N	CH	R	P	M
16	M6	6	M16x1.5	21	12	17,27	18	6	16	82	93	43	22	17	26	9	5	M5	53	109
20	M8	8	M22x1.5	27	16	21,27	25,5	8	20	95	111	51,5	24	20	32	12	7	1/8" G	67	131
25	M10x1.25	10	M22x1.5	30	16	26,5	28,5	8	22	104	118	52	28	22	36	12	9	1/8" G	68	140

EB Ekleme Bağlantı

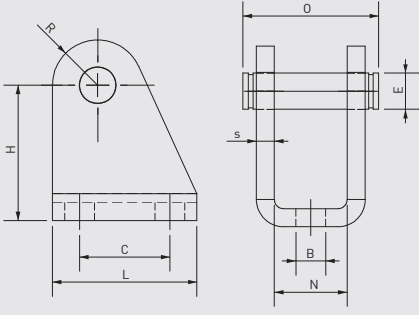

Silindir Ø mm	B H13	E f8	C JS13	H ±0.2	L	N E9	O	R max	S ±0.2
8-10	4,5	4	12,5	24	20	8,1	17	5	2,
12-16	5,5	6	15	27	25	12,1	23	7	3
20-25	6,6	8	20	30	32	16,1	29,5	10	

FB Flanş Bağlantı

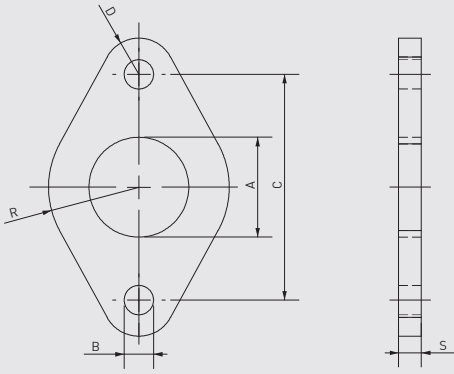

Silindir Ø mm	A +0.3 +0.1	B H13	C JS13	R ±0.2	G ±0.2	S ±0.2
8-10	12	4,5	30	11	5	3
12-16	16	5,5	40	15	6	4
20-25	22	6,6	50	20	8	5

AB Ayak Bağlantı

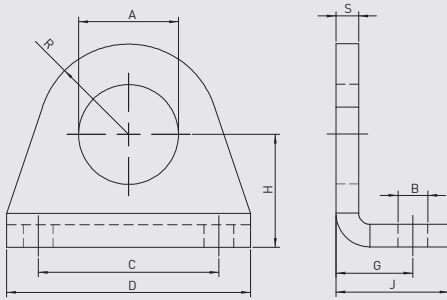

Silindir Ø mm	A +0.2 +0.1	B H13	C JS13	D	G +0.3 0	H ±0.2	J	R max	S ±0.2
8-10	12	4,5	25	35	11	16	16	1	
12-16	16	5,5	32	42	14	20	20	12	
20-25	22	6,6	40	54	17	25	25	20	5

ÇB Çatal Bağlantı

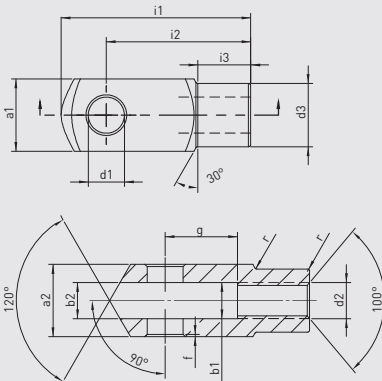

Silindir Ø mm	d1 H9	g ±0.5	a1 h11	a2 +0.3 -0.16	b1 B13	b2	d2 6H	d3 ±0.3	f ±0.2	i1 ±0.5	i2	i3 ±0.2	r
8-10	4	8	8	8	4	4	M4x0.70	8	0,5	21	16	6	0,5
12-16	6	12	12	12	6	6	M6x1.00	10	0,5	31	24	9	0,5
20	8	16	16	16	8	8	M8x1.25	14	0,5	42	32	12	0,5
25	10	20	20	20	10	10	M10x1.25	18	0,5	52	40	15	0,5

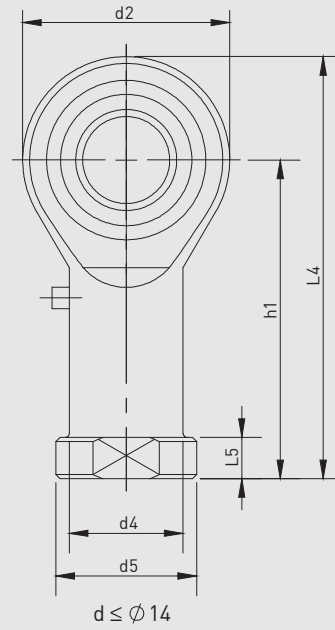
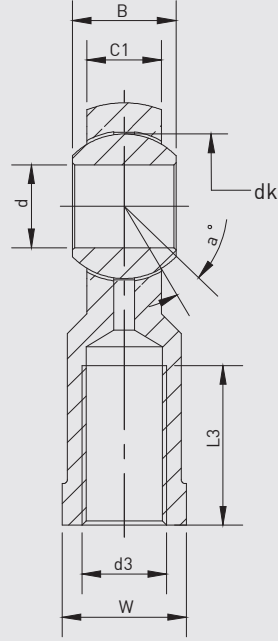

Parça No.	Ölçüler (mm)													
	d	d3 6H	B	C1	w	L3 min	d2	L4	h1	L5	d4	d5	dk	a°
KMB 6	6	M6x1.0	9	6,75	11	12	18	39	30	5	10	13	12,7	13
KMB 8	8	M8x1.25	12	9	14	16	22	47	36	5	12,5	16	15,875	14
KMB 10-1	10	M10x1.25	14	10,5	17	20	26	56	43	6,5	15	19	19,05	13