

**CETOP RP 53P-43P
PNÖMATİK SİLİNDİRLER
PNS SERİSİ Ø125 - Ø320**





PNS SERİSİ

CETOP RP 53P - Ø125 - Ø320

ALÜMİNYUM BORULU
YASTIKLAMALI SİLİNDİR

ELOKSAL KAPLAMASI SAYESİNDE
MAKSİMUM KEÇE PERFORMANSI.

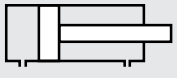

PNS: ÇİFT ETKİLİ
SİLİNDİR

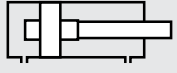

PNS-Y: ÇİFT ETKİLİ
YASTIKLAMALI SİLİNDİR



PNS-D: ÇİFT ETKİLİ
ÇİFT MİLLİ SİLİNDİR

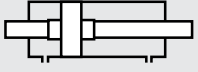

PNS-YD: ÇİFT ETKİLİ
YASTIKLAMALI ÇİFT MİLLİ SİLİNDİR

Sipariş örneği:

PNS-Y

Ürün kodu

125-0200

Silindir Ø Strok

EYB

Silindir
bağlantıları

K1 M2

Standart dışı
varyasyonlar

Standart dışı varyasyonlar:

- R1: Paslanmaz çelik silindir mili (SS 304, SS 316)
- R2: Paslanmaz çelik saplamalar (SS 304, SS 316)
- R3: Kapak bağlantı civataları paslanmaz çelik (SS 304)
- R4: Mil ucu somunu paslanmaz çelik (SS 304)
- M1: Silindir milinde uzatılmış erkek dış
- M2: Dişi dış açılmış silindir mili
- M3: Silindir mili özel dış ölçüsü
- M4: Uzatılmış silindir mili
- K1: Maks. 150°C için sızdırmazlık elemanları (viton)
- K2: Mil keçesi NBR+PA
- K3: Sızdırmazlık elemanları NBR
- K4: Mil keçesi viton

Çalışma akışkanı:

Filtrelenmiş ve yağlanmış hava

Çalışma sıcaklık derecesi:

NBR+Poliüretan (PU) : (-20°C) - (+80°C)
Viton (FKM) : (-30°C) - (+150°C)

Maksimum çalışma basıncı:

10 Bar

Kuvvet değeri:

Silindir Ø mm	Mil Ø mm	İtme ve Çekme kuvvetleri (6 Bar)	
		İtme kuvveti (N)	Çekme kuvveti (N)
125	32	7360	6880
160	45	12064	11110
200	45	18850	17890
250	50	29450	28270
320	63	48250	46380

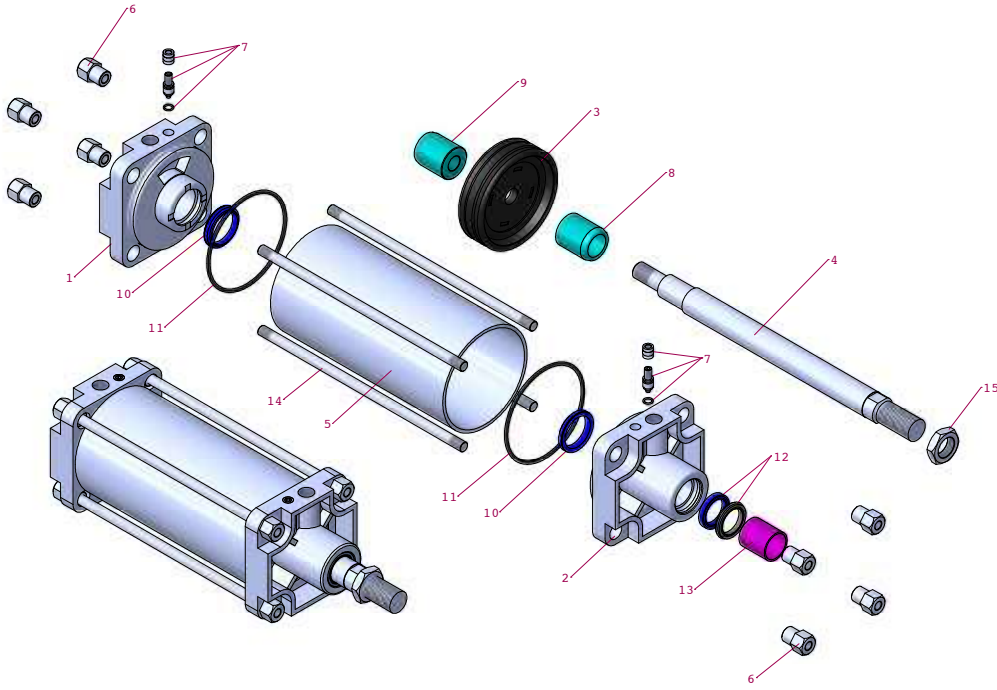
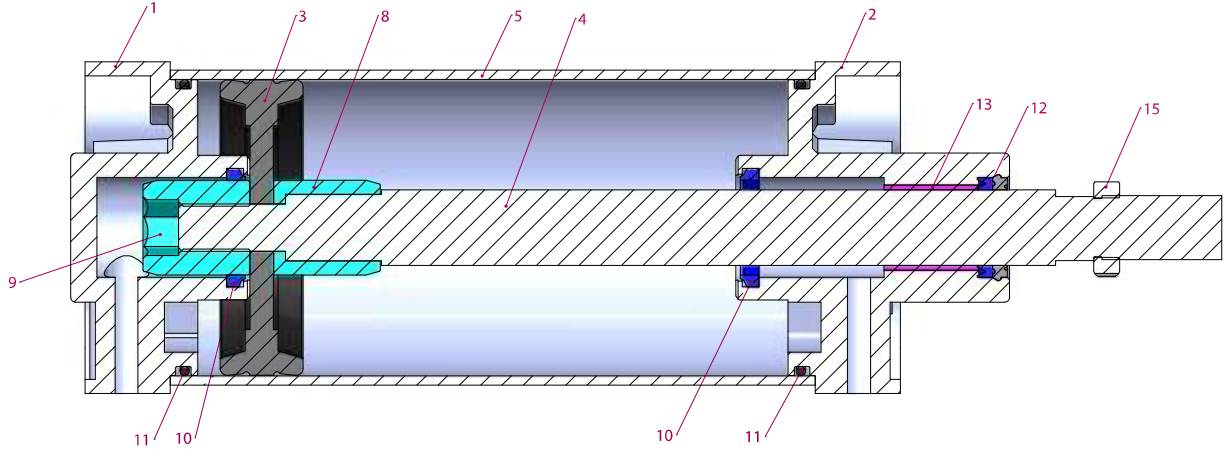

No	Malzeme adı	Malzeme özelliği	Adedi
1	ka kapak	Alüminyum	1
2	Ön kapak	Alüminyum	1
3	Piston keçesi	NBR	1
4	Piston mili	CK45 sert krom kaplamalı	1
5	Boru	Al Mg Si 0,5 + Eloksal kaplamalı	1
6	T-somun	Galvaniz kaplamalı çelik	8
7	Yastıklama vidası	Pirinç + AISI 303 NBR	2
8	Yastıklama borusu	Alüminyum	1
9	Yastıklama dişlisi	Alüminyum	1
10	Yastıklama keçesi	PU	2
11	Kapak O-ringi	NBR	2

No	Malzeme adı	Malzeme özelliği	Adedi
12	Mil keçesi	HYTREL + PU	1
13	Yataklama burcu	CSB-40	1
14	Saplama	Galvaniz kaplamalı çelik	4
15	Somun	Galvaniz kaplamalı çelik	1

Not:

Yastıklamasız modellerde 7, 8, 9, 10 numaralı parçalar yoktur.
9 no'lu parça yerine fiberli somun ve pulu vardır.

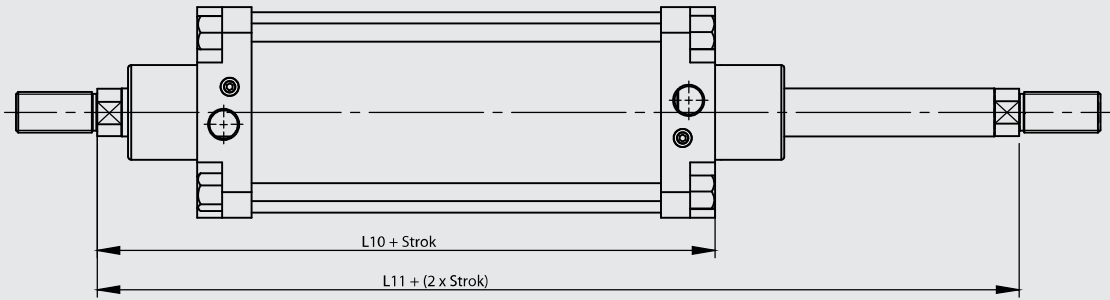
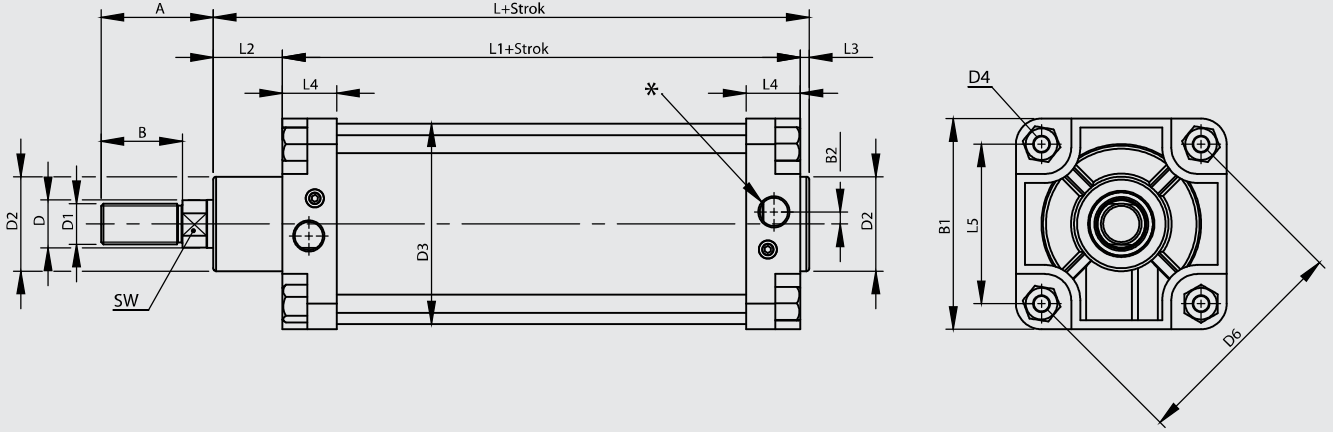

Silindir Ø mm	A	B	B1	B2	D Ø	D1	D2 Ø	D3 Ø	D4	D6 Ø	L	L1	L2	L3	L4	L5	L10	L11	SW	*
125	70	48	140	15	32	M27x2	63	133	M12	150	208	150	48	6	36	106	220	290	2	
160	102	72	180	22	45	M36x2	80	170	M14	190	235	170	55	10	46	134,4	255	340	41	G3/4"
200	102	72	220	25	45	M36x2	80	210	M16	234	257	180	65	12	46	165,5	275	370	41	G3/4"
250	114	84	270	25	50	M42x2	100	262	M20	288	289	200	75	14	50	203,7				
320	126	96	340	30	63	M48x2	110	336	M24	360	326	220	90	16	56	254,6	340	460	55	G1"

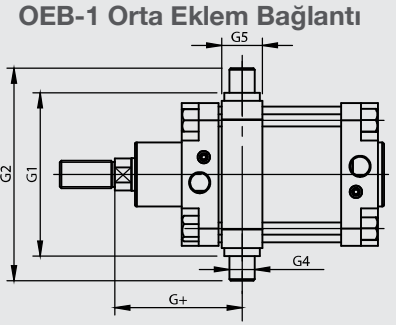
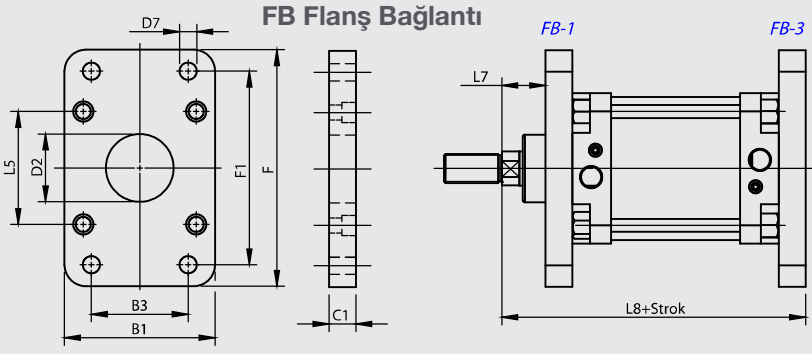

OEB-1 : Sabit Bağlantı

AB Ayak Bağlantı

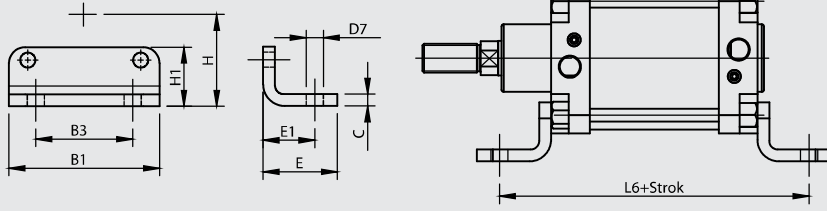

OEB-3 Orta Eklem Bağlantı

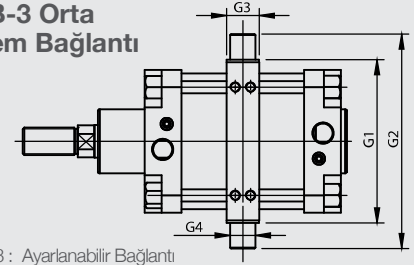

OEB-3 : Ayarlanabilir Bağlantı

EB Eklem Bağlantı

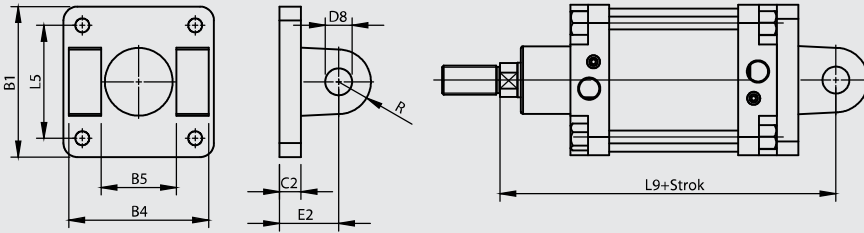

DMB Destek Masfal Bağlantı

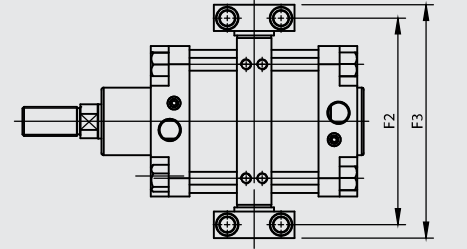

YB Yer Bağlantı

EYB Eklem Yer Bağlantı

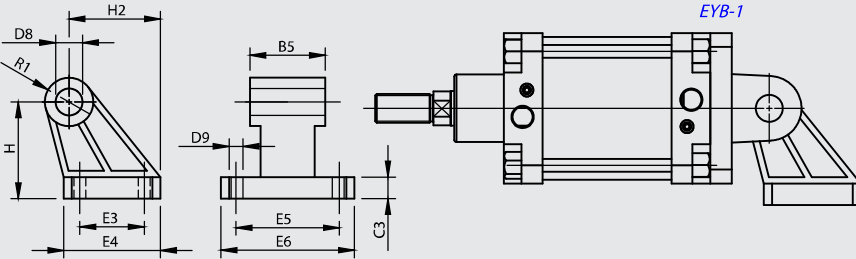

Silindir Ø mm	B1	B3	B4	B5	C	C1	C2	C3	D2 Ø	D7 Ø	D8 Ø	D9 Ø	E	E1	E2	E3	E4	E5	E6	F	F1	F2	F3	F4
		JS14	h14	H14					H11	H13	H9	H13				JS14		JS14		JS14			H13	
125	140	90	130	70	11	25	20	20	63	16	25	14	69	50	55	60	90	94	124	220	180	192	217	20
160	180	115	170	90	13	25	22	25	80	18	30	14	87	65	60	88	126	118	156	280	230	245	280	26
200	220	135	170	90	15	25	25	30	80	22	30	18	95	70	60	90	130	122	162	320	270	295	330	26
250	270	165	200	110	20	25	25	35	100	26	40	22	105	75	70	110	160	150	200	390	330	375	420	
320	340	200	220	120	23	30	30	40	110	33	45	26	125	85	80	122	186	170	234					

Silindir Ø mm	F5 Ø	F6	F7	F8	F9	F10	F11	G1	G2	G3	G4 Ø	G5	G+	H	H1	H2	L5	L6	L7	L8	L9	R	R1
	H13			±0,3				h14			e9			JS16									
125	14	50	13	50	75	24.5	16	160	210	32	25	38	125	90	55	85	106	250	45	245	275	30	22.5
160	18	60	17	60	92	36	22.5	200	264	40	32	48	155	115	70	116	134.4	300	60	280	315	32	31.5
200	18	60	17	60	92	36	22.5	250	314	40	32	48	165	135	80	125	165.5	320	70	300	335	35	31.5
250	22	70	21.5	90	140	45	27.5	320	400	50	40	62	186	165	100	153	203.7	350	80	330	375	45	40
320	26	80	25.5	100	150	55	32.5	400	500	60	50	65	210	200	120	182	254.6	390	90	370	420	54	45

FB Flanş Bağlantı

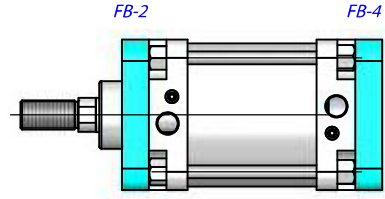
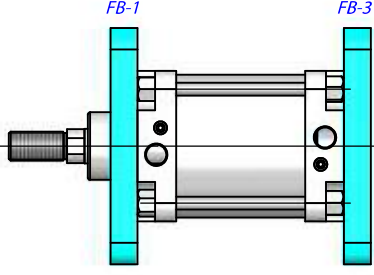

AB Ayak Bağlantı

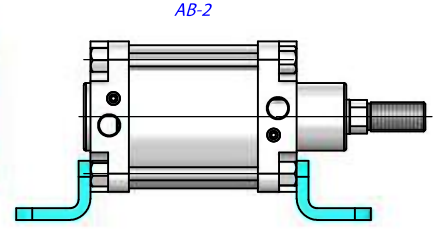
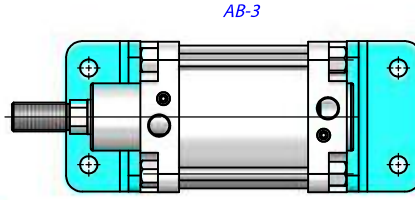
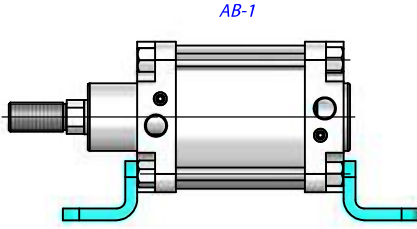

EB Ekleme Bağlantı

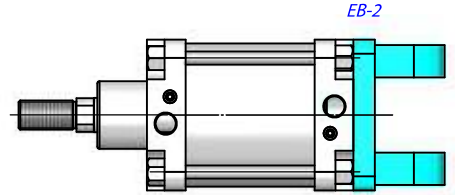
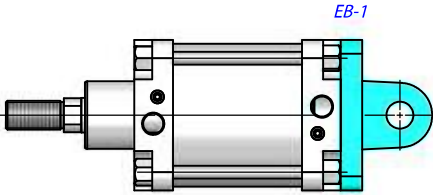

EYB Ekleme Yer Bağlantı

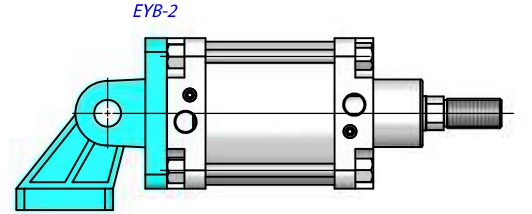
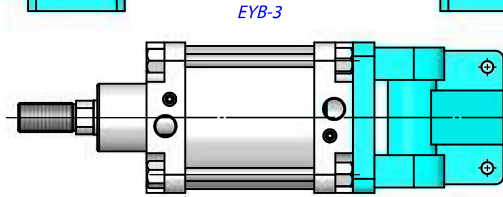
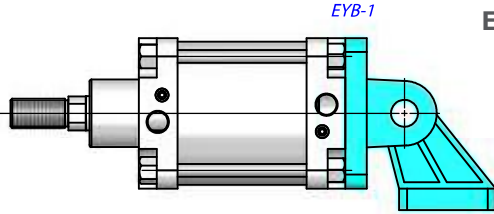

OEB Orta Ekleme Bağlantı

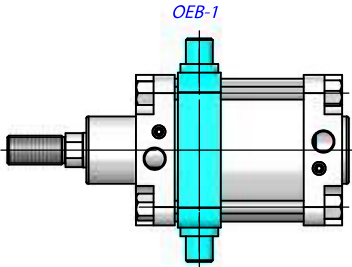

OEB-1-2 Sabit Bağlantı

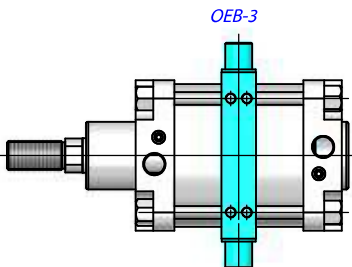
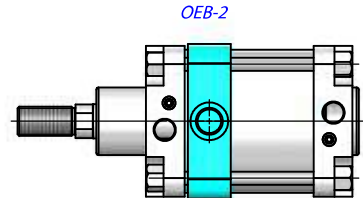

OEB-3-4 Ayarlanabilir Bağlantı

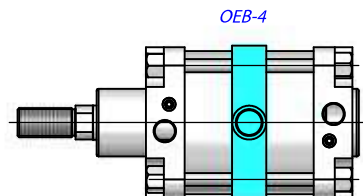

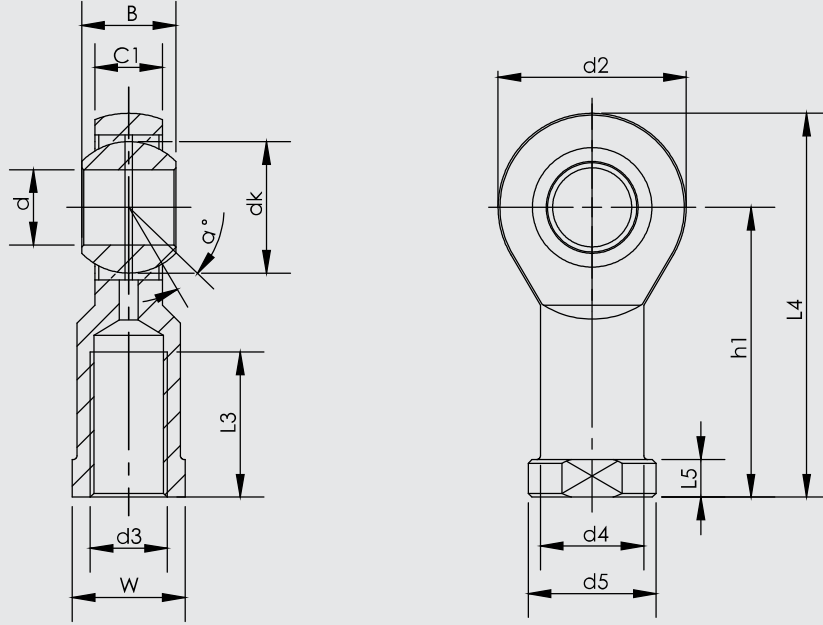

Parça No.	Ölçüler (mm)													
	d	d3 6H	B	C1	W	L3 min	d2	L4	h1	L5	d4	d5	dk	a°
KMB 28	28	M27x2.0	35	24	41	48	66	136	103	14	37	46	47.6	15
KMB 30-1	30	M27x2.0	37	25	41	51	70	145	110	15	40	50	50.8	17
KMB 30	30	M30x2.0	37	25	41	51	70	145	110	15	40	50	50.8	17
KMB 35	35	M36x2.0	43	28	50	56	81	165.5	125	17	46	58	57.1	16
KMB 35 UK	35	M36x3.0	25	21	50	60	82	166	125	15	47	58	47	6
KMB 40 UK	40	M39x3.0	28	23	55	65	92	188	142	18	52	65	53	7
KMB 40	40	M42x2.0	49	33	55	60	91	187.5	142	19	53	65	66.6	17
KMB 50 UK	50	M45x3.0	35	30	65	68	112	216	160	20	62	75	66	6
KMB 50	50	M48x2.0	60	45	65	65	117	218.5	160	23	65	75	82.5	12

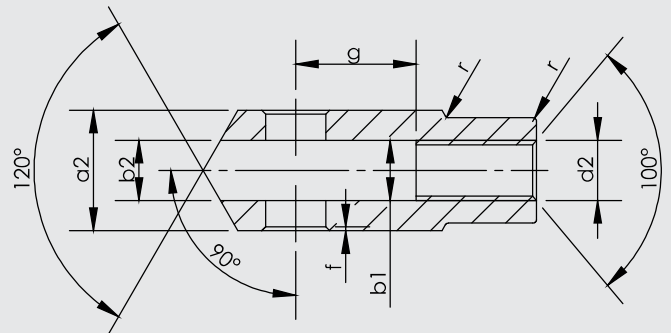
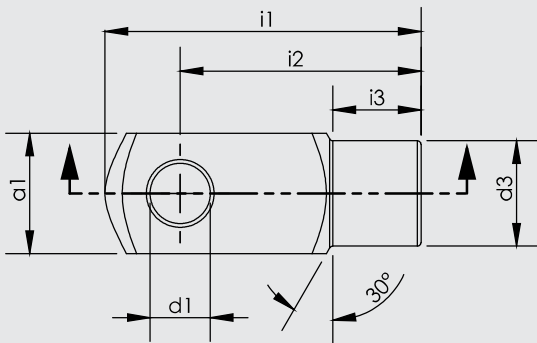

Silindir Ø mm	d1 H9	g ±0,5	a1 h 11	a2 +0,3 -0,16	b1 B 13	b2	d2 H	d3 ±0,3	f ±0,2	i1 ±0,5	i2	i3 ±0,2	r
125	25	50	50	50	25	25	M27x2	42	1.5	132	100	36	1.5
160	35	72	70	70	35	35	M36x2	60	2	188	144	41	2
200	35	72	70	70	35	35	M36x2	60	2	188	144	41	2
250	40	96	80	80	40	40	M42x2	70	3	220	168	43	3
320	50	111	90	90	50	50	M48x2	80	3	250	192	44	3